

MARK ECOFLEX

0660400_R10



INSTRUCTIONS FOR USER

Warning

Incorrect installation, adjustment, alteration, repair or maintenance work may lead to material damage or injury. All work must be carried out by certified, qualified professionals. If the appliance is not positioned in accordance with the instructions, the warranty shall be rendered void. This appliance is not intended for use by children or persons with a physical, sensory or mental handicap, or who lack the required experience or expertise. Children must be supervised to ensure that they do not play with the appliance.

If you have questions concerning the use of your boiler or heating system, please ask your installer. It is in your own interest and that of the installer that you are aware of how to operate your boiler and heating system safely and efficiently.

Operation

Water, coming from the radiators or from the DHW unit is heated in the aluminium heat exchanger. The CH or DHW pump guarantees circulation of water. The air needed for combustion is sucked in by a rpm controlled fan. At low boiler temperatures the fluegasses can be cooled down sufficiently for condensation of the water. This water is drained to the sewer via a built in syphon. This drainage may never be blocked. A burner controller with built in micro-processor takes care of the electrical regulation of the boiler.

Topping up

The built in manometer indicates if the water pressure is sufficient. As soon as the water pressure drops below 1 bar topping up is necessary. If topping up becomes a regular occurrence, your installation should be checked by an installer.

Disconnect from the main. Connect the filling hose to the cold water tap and to the fill and drain valve of the boiler. Before tightening the coupling in the installation slowly fill the hose with water allowing present air to escape. Now open the fill and drain valve and slowly fill the installation till a pressure between 1.5 and 2.0 bar is reached. When finished connect again to the main.

Bleeding

To remove any air present in the heating system and boiler, bleeding is necessary. Disconnect from the main. Open all the radiator valves. Bleed the air from all the radiators starting with the ones at the lowest point in the system. After bleeding, check the water pressure and top up if required (if water pressure has dropped below 1 bar). Connect to the main again.

Starting the boiler

Please ask your installer how to start the boiler. Depending on how your heating system is controlled, this could be via an external timeclock, thermostat, switch or otherwise. Once the boiler Volt-free enable contacts are closed, the boiler will commence its starting sequence.

Boiler flow temperature

The burner controller adjusts the flow temperature between 20 ° and 85 °C. The temperature setting can be changed using the control panel. The installation manual provides the instructions for setting the flow temperature.

DHW (Hot Water) temperature (if applicable)

From the factory the DHW temperature is set to a value of 60 °C. This set value can be changed into a value between 35 and 65 °C with help of the buttons on the control panel. If the DHW device has a thermostat the DHW temperature can be adjusted by setting this thermostat.

Switching off the boiler

During summer time the room thermostat can be set to a lower value to turn off the boiler. During winter or during a longer periode of absence this temperature never should be set to a lower value than 15 °C. Don't switch of the power. During a period of frost all the radiators should be partly or totally opened to avoid danger of freezing.

The integrated pump control wil activate the pump every 24 hours during a short period even if no demand is present. This prevents the pump jamming. Only when work on the boiler is carried out may the main electricity supply and the gas supply be turned off (your installer can show where these are located).

Errors

If an error occurs first check the following

- Is the room thermostat properly set?
- Is the boiler connected to the main? Power supply present?
- Is the gas valve opened?
- Are the radiator valves open?
- Is the waterpressure in the installation higher than 1 bar?
- Is the Installation bled thoroughly?

An error is indicated by a flashing code on the display. It is very important for the sake of a correct diagnosis to mention this flashing code when calling your installer. Reset the burner controller by pressing the OK button on the control panel. If the error more often occurs contact your installer.

Maintenance

A yearly inspection of the boiler to be done by your installer is necessary. The life-time and the reliability of the installation are improved by doing so. The casing of the boiler can be cleaned with a soft cloth (no abrasives). Never use solvents like thinner!

Caution

The air supply (for air needed for combustion) and the flue parts are essential parts for safe and efficient functioning of the boiler. Changes on these systems by non qualified persons are not allowed just like the settings of the gasvalve. The gas/air ratio is set to a lambda value of approximately 1.26. This corresponds with a CO₂ level of 9,3 % (full load).

For further information see installation manual.

The information in this document is subject to change without notice. The most recent version of this manual is always available at www.markclimate.com/downloads.

I DESCRIPTION BOILER

EN

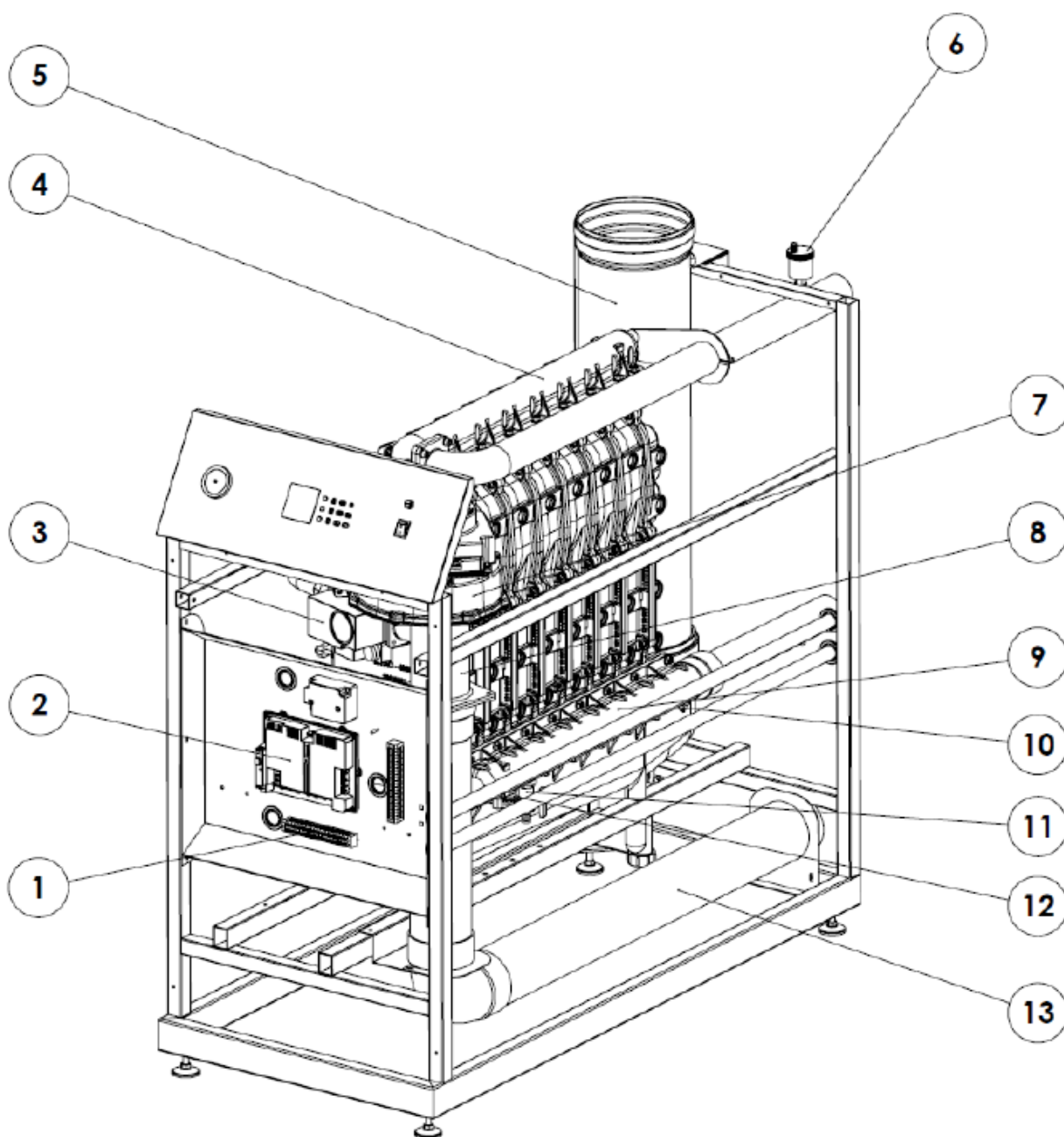

- 1 Terminal strip
- 2 Boiler controller (Maxsys)
- 3 Gas valve
- 4 Flow
- 5 Exhaust
- 6 Automatic air vent
- 7 Fan

- 8 Venturi
- 9 Return
- 10 Return NTC
- 11 Fill and drain valve
- 12 Water pressure sensor
- 13 Air supply

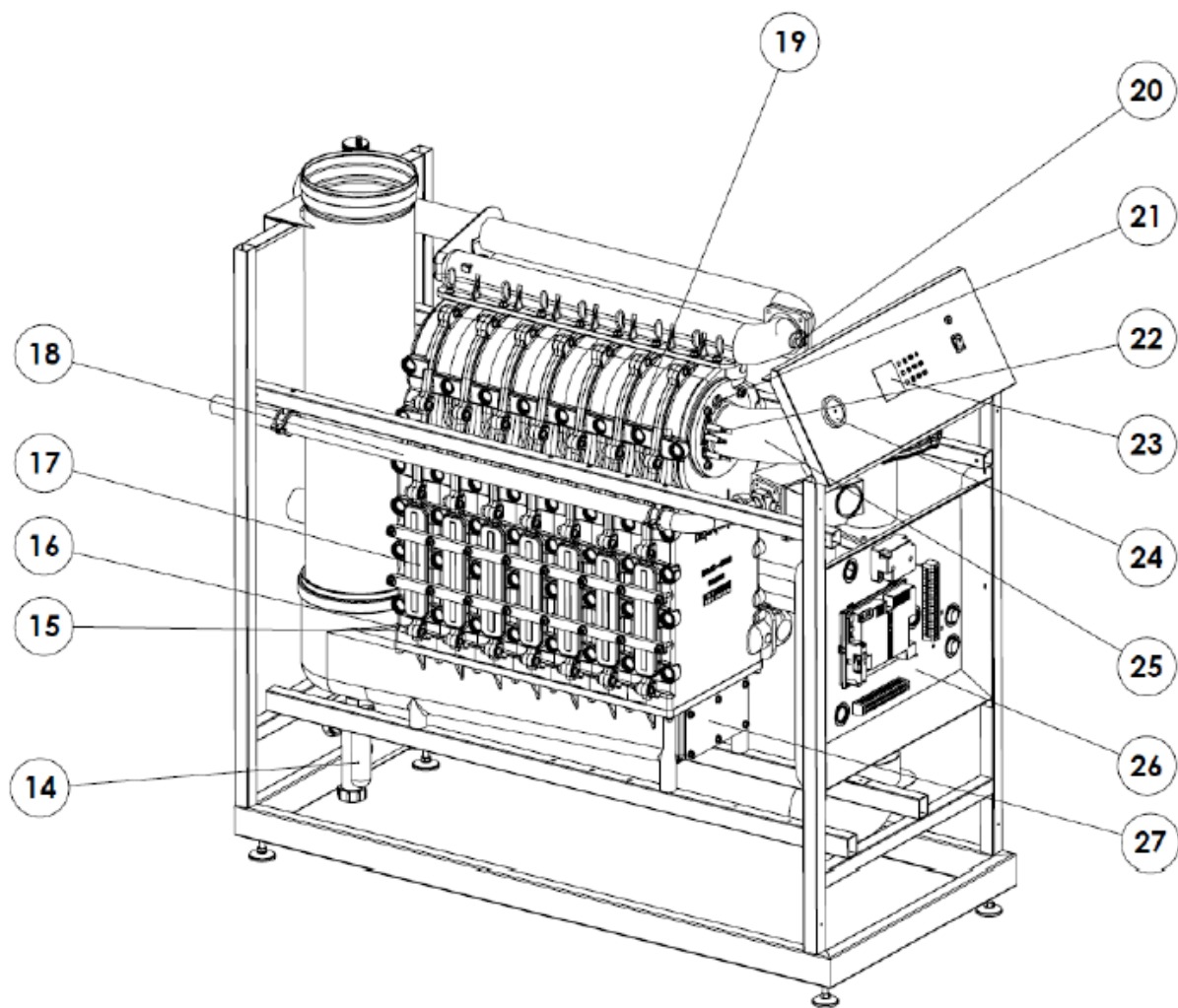

- | | |
|---------------------------|--------------------------------------|
| 14 Syphon | 21 Sight glass |
| 15 Syphon pressure switch | 22 Ignition and ionization electrode |
| 16 Fluegas NTC | 23 Display LCD |
| 17 Inspection cover | 24 Manometer |
| 18 Gas pipe | 25 Burnerhood |
| 19 Overheat limiter Flow | 26 Air pressure switch |
| 20 NTC | 27 Sump inspection cover |

2 TECHNICAL DATA

		168-5	210-6	252-7	294-8
Central heating					
Nominal input max load (H _i)	kW	168	210	252	290
Nominal input min load (H _i)	kW	33,6	42	50,4	58,8
Nominal output max load 80-60 °C	kW	163,6	204,5	245,4	282,5
Nominal output min load 80-60 °C	kW	32,6	40,7	48,9	57
Efficiency max load 80-60 °C (Hi)	%	97,4	97,4	97,4	98,4
Efficiency min load 80-60 °C (Hi)	%	97	97	97	97
Efficiency max load 50-30 °C (Hi)	%	102,8	102,8	102,8	103,9
Efficiency 30% load 30 °C (return) (Hi)	%	107,5	107,5	107,5	107,5
Flue gas					
Temperature flue-gas max load 80-60 °C	°C	70-75	70-75	70-75	70-75
Temperature flue-gas min load 80-60 °C	°C	65-70	65-70	65-70	65-70
Flow flue-gasses at max load G25	m ³ /h	275	343	412	474
Flow flue-gasses at min load G25	m ³ /h	55	69	83	96
Maximum flue-resistance	Pa	150	150	150	150
Emission CO (Gaskeur SV)	ppm	38	39	37	35
Emission NO _x (Gaskeur SV)	ppm	29	29	29	29
NO _x class					
Types B23,C13,C33,C53,C63		yes	yes	yes	yes
Gas					
Also see 7.1					
Gasflow max load G25	m ³ /h	20,2	25,2	30,3	34,9
Gasflow min load G25	m ³ /h	4,04	5,05	6,05	7,06
Gas flow max load G25.3	m ³ /h	19,75	24,65	29,6	34,05
Gas flow min load G25.3	m ³ /h	3,95	4,93	5,92	6,9
Gasflow max load G20	m ³ /h	17,4	21,8	26,2	30,2
Gasflow min load G20	m ³ /h	3,49	4,36	5,23	6,1
CO ₂ content max load G25/G20/G25.3	%	9,3	9,3	9,3	9,3
CO ₂ content min load G25/G20/G25.3	%	9,1	9,1	9,1	9,1
O ₂ content max load G25	%	3,90 +0,10-0,30			
O ₂ content min load G25	%	4,30 +0,35-0,20			
O ₂ content max load G25.3	%	3,95 +0,10-0,35			
O ₂ content min load G25.3	%	4,35 +0,35-0,25			
O ₂ content max load G20	%	4,25 +0,10-0,35			
O ₂ content min load G20	%	4,60 +0,40-0,20			
Water					
Maximum flow temperature	°C	85	85	85	85
Content heat-exchanger	ltr	16,9	21,3	24,7	30,2
Minimum/maximum operating pressure	bar	0,8/6	0,8/6	0,8/6	0,8/6
Hydraulic resistance	mbar	90	96	99	103
(DT20 nominal flow at full load 80-60 °C					
Maximum DT max load/min load	°C	25/35	25/35	25/35	25/35
Maximum waterflow	m ³ /h	14,1	17,6	21,1	24,3
Weight					
Mass of heat exchanger with manifolds and sump	kg	82	99	116	133
Total mass boiler	kg	193	210	227	244

Sizes of casing					
Width	mm	602	602	602	602
Depth including connections	mm	1463	1463	1463	1463
Height including chimney connection	mm	1311	1311	1311	1311
Height	mm	1307	1307	1307	1307
Electrical					
Protection	IP	00B	00B	00B	00B
Supply life+neutral	V/Hz	230/50	230/50	230/50	230/50
Maximum power-consumption	W	1150	1150	1150	1150
Standby power-consumption	W	5	5	5	5
Fuse	A	5	5	5	5

2.1 Component Matrix

Overview of main components used in EcoFlex-series

Part	168-5	210-6	252-7	294-8
Boiler control Honeywell Maxsys	S4966V2052	S4966V2052	S4966V2052	S4966V2052
Display (user interface)	DSP 49G2193	DSP 49G2193	DSP 49G2193	DSP 49G2193
Fan MVL 230 VAC	GIG170-AB31-42	GIG170-AB31-42	GIG170-AB31-42	GIG170-AB31-42
Gas-valve Honeywell 230 VAC	VR420VE5001-0000	VR425VE5022-0000	VR425VE5022-0000	VR425VE5022-0000
Venturi Honeywell	VMU185A1009	VMU300A1004	VMU335A1000	VMU335A1000
Texi Burner round 128mm Worgas	L=341	L=425	L=509	L=593
Silencer air-inlet	yes	yes	yes	no
Silencer flue-gas round 200mm	yes	yes	yes	yes
NTC 12 k L=50	3	3	3	3
NTC 12 k OTC	optional	optional	optional	optional
Water low pressure device 1,6/0,8 bar	yes	yes	yes	yes
Pressure difference switch 40 Pa in and 25 Pa out	yes	yes	yes	yes
Syphon pressure difference switch 8,3 mbar out	yes	yes	yes	yes
Gas pressure switch : in 11,7-14,3 and out 8,6-11,4 mbar	yes	yes	yes	yes

3 DIMENSIONS

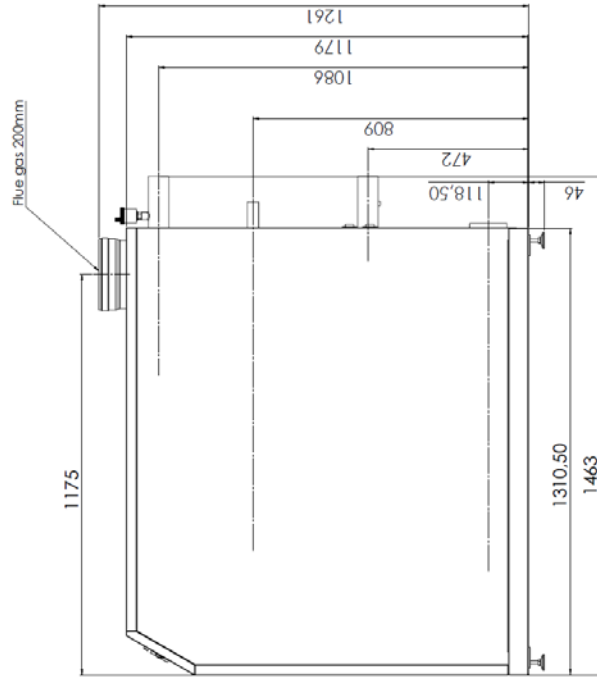
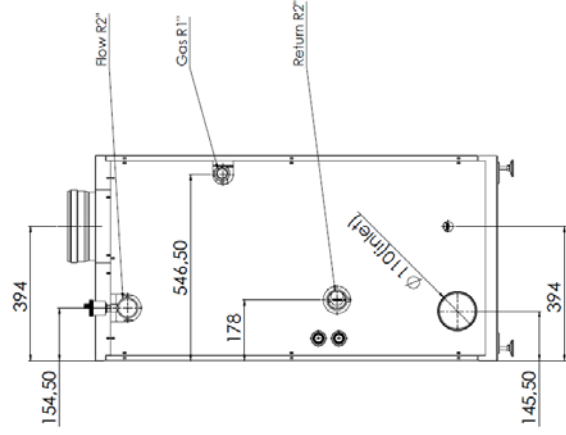
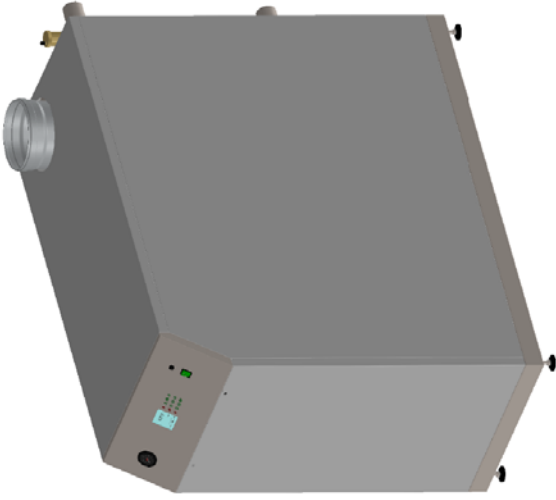

168-210-252-294

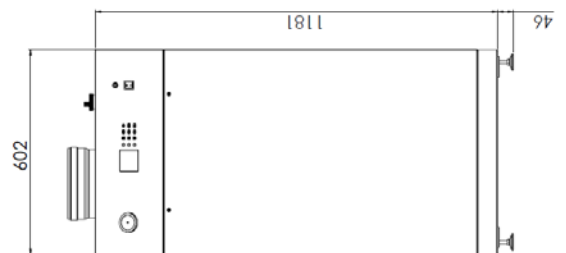

The appliance is not to be used by children or persons with reduced physical, sensory or mental capabilities, or lack of experience and knowledge. Children being supervised must not play with the appliance.

In the case of failure or malfunction of the appliance, do not attempt to repair it yourself. Please contact your installer. Repairs must only be carried out by qualified technicians. Failure to comply with these requirements can compromise the safety of the appliance.

4 OPERATION

4.1 General

The EcoFlex is a floor standing boiler, equipped with a cast aluminium heat-exchanger. During heat demand the controller activates the pump. The controller checks the air pressure switch (zero check) and increases the fan speed to perform an airflow-check. Once the air pressure switch closes the fan speed increases to ignition speed and a 30 second pre-purge is performed. The water pressure sensor, gas pressure switch and siphon pressure switch are checked. When all pressure switches are closed and the water pressure is ok, the ignition is started.

The air needed for combustion is taken in from the outside (if room sealed) or the boiler house (type B flue installation) by the fan. The air is transported through a gas/air mixing device creating a negative pressure. This negative pressure is an indication of the amount of air being transported. The negative pressure is supplied to the gas-valve by an internal tube. The gas valve automatically adjusts the amount of gas that will be injected into the venturi and that will be mixed with the air-flow. This mixture is supplied to the burner.

Ignition and flame-control of the mixture is done by two electrodes mounted on the burner hood. Temperature control and safeguarding is done using 2 NTC's. The boiler monitors the sensors continuously in order to control operation and ensure safe operation.

4.2 Central Heating (CH)

4.2.1 On-off room thermostat

As standard the boiler is programmed for using an on-off room thermostat. The room thermostat has to be connected to the pin nrs. 1+ 2 on the terminal strip. Open Therm will be recognized if connected on 1 + 2. The desired flow temperature is adjustable, but as standard is set to 85 °C.

At CH heat request from the room thermostat (and no DHW heat request present) the CH-pump is activated after 10 seconds. The controller will adjust the burner-input in such a way that a flow-temperature of 85 °C towards the CH-circuit is achieved.

Warning: do not supply any voltage to these terminals as you may damage the controller

4.2.2 Optional 0-10V

The boiler may be controlled using a 0-10V DC signal. Connect the negative (0V DC) to No. 3, and the positive (0-10V DC) to No.4 on terminal strip C2.

A loop of wire must be placed between the pin nrs. 1 and 2 of terminal strip C2.

In the technician menu, enable 0-10V in the advanced CH settings menu by setting, CH request to either 0-10V DC % or 0-10V DC SP.

4.2.2.1 0-10Vdc % power control

A value between 2 and 10Vdc generates a CH power demand proportional to this value between 0 and 100% (0% = minimum load, 100% = nominal load). The heat demand is removed when the control signal falls below 1 volt. The setpoint of maximum flow temperature is set to 90°C.

In the user/technician menu, diagnostics, boiler information the actual voltage input and target power are being displayed.

4.2.2.2 0-10Vdc Setpoint

A value between 2 and 10Vdc generates a CH setpoint demand proportional to this value between CH minimum flow temperature and maximum CH flow temperature. The heat demand is removed when the control signal falls below 1 volt.

The minimum and maximum CH flow temperature can be set in the technician menu, advanced CH settings, CH temperatures.

Technician menu ----> 1 advanced settings ----> 2 CH temperatures ----> 1 absolute max. temperature
Setting higher than 90 degrees is not allowed.

In the user/technician menu, diagnostics, boiler information the actual voltage input and boiler setpoint are being displayed.

Caution: Ensure that the 0-10V DC signal is free from electrical interference!

4.2.3 Outside Temperature Control OTC (optional)

The boiler may use an outdoor sensor to provide weather compensation (OTC).

To activate weather compensation, connect an outdoor sensor to numbers 5 and 6 on the terminal strip C2. Pin numbers 1 and 2 have to be bridged by a wire. Alternatively those pin numbers (1 and 2) can be used for connecting room thermostat on/off. In the technician menu, advanced CH settings, CH request, OTC only must be selected. The outdoor sensor is then automatically detected by the controller. The parameters corresponding with A-E in the figure below can be set in the technician menu (advanced CH settings).

CH Setpoint

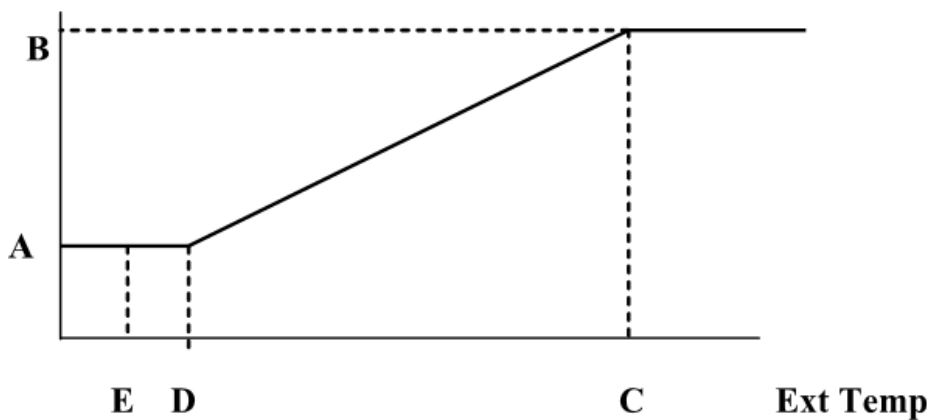

- A OTC offset: minimum CH setpoint value
- B OTC setpoint maximum: maximum CH setpoint value
- C OTC weather cold: external temperature value at which the maximum CH value will be used.
- D OTC weather warm: external temperature value at which the minimum CH value will be used
- E OTC warm weather shutdown: external temperature value at which the CH demand will end

In the user menu an eco setpoint reduction (night reduction) can be set. A day, week and weekend will also be available (on , eco off)

The outdoor sensor is available as an optional accessory. The sensor should be installed on the north-side of the building at a height of approximately 2 meters.

Notice : The resistance of the outdoor NTC should be 12 kOhm at 25 °C.
Also see table of resistance for NTC's at 6.7.2

4.2.4 Optional digital communication

The boiler supports digital communication with room thermostats using Open-Therm communication protocols (automatically recognised if connected to pins 1 + 2 on terminal strip C2, also see 4.2.1).

4.2.5 Slow start

The boiler uses a “slow start” procedure to prevent the boiler from supplying excessive power in low load situations.

After “zero check” APS and closure APS with pre purge ignition starts. Following a stabilization period, the boiler modulates down to low capacity and maintains this capacity for 1 minute. Subsequently the boiler power increases at a rate of 4 °C/min until maximum capacity or set temperature has been reached. Once heat demand has finished the burner will turn off following a set post purge period. The graph below illustrates this;

Slow start sequence

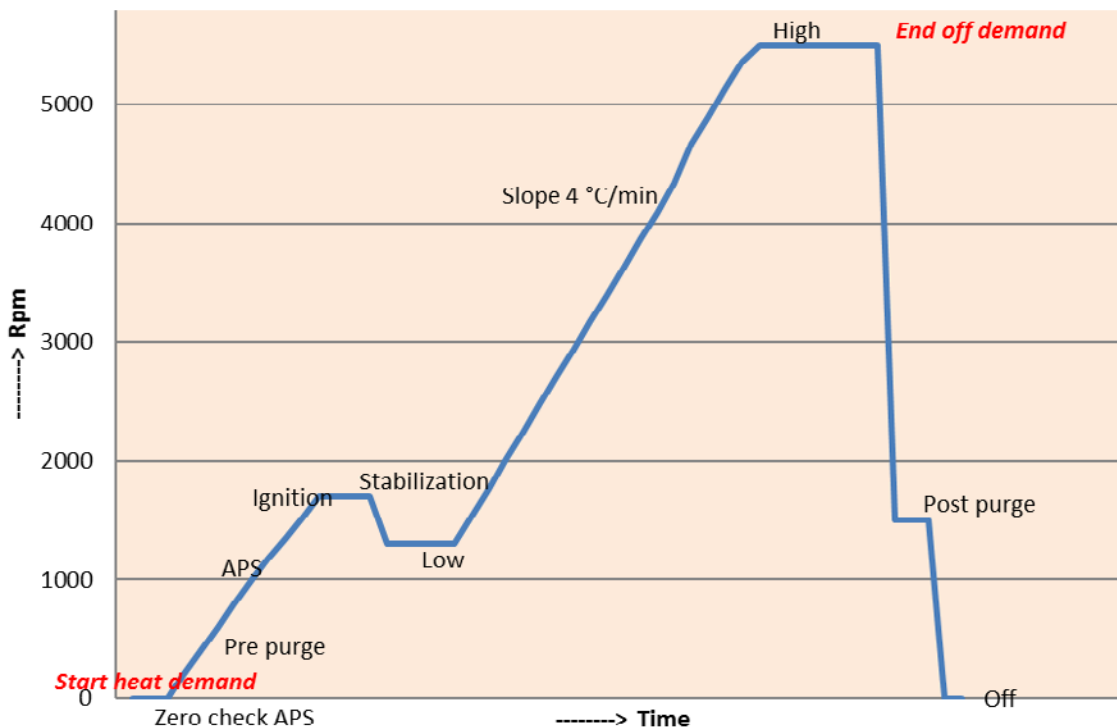

4.2.6 Protection against insufficient flow through boiler

If the requirements of 6.3.2 are fulfilled the boiler will protect itself against insufficient flow. This is done by checking the difference in temperature between flow and return (so called ΔT).

In a low flow scenario the ΔT will rise rapidly. The ΔT safe-guarding principle is as follows;

At $\Delta T > 22$ the boiler starts modulating

At ΔT between 22 and 27 the boiler continues modulating

At $\Delta T > 27$ boiler the fan speed will be reduced until $\Delta T < 25$

4.3 Domestic Hot Water preparation (DHW)

4.3.1 External storage tank with thermostat (electric 3-way valve)

As standard the DHW configuration is factory pre-set for an external storage tank + tank thermostat. For hydraulic connection of an external storage tank to the boiler via an electric 3-way valve one should either use:

- the default configuration 2 pumps: 230 VAC DHW pump (terminal strip C1: 6,7,8) and CH pump (terminal strip C1: 9,10,11)
- an electric 3-way valve with a maximum travel time of 255 sec. (terminal strip C1: 6,7,8,9). At the end of the travel time in either direction DHW or CH the 230 VAC on the 3-way valve will be switched off. The 2 wires of the tank thermostat must be connected to numbers 7 and 8 on terminal strip C2. In the case of using an electric 3-way valve adjust the setting in the technician menu, system settings, boiler parameters, number of pumps to: pump and 3-way valve.

The 3-way valve travel time can be changed in the technician menu, system setting, boiler parameters, 3-way valve travel time.

4.3.2 External storage tank with NTC sensor

In case the storage tank is equipped with an NTC sensor, adjust setting in technician menu, advanced DHW settings, DHW request to sensor.

Notice: The resistance of the NTC sensor must have a value of 12 kOhm at 25 °C.

The 2 wires of the tank NTC sensor need to be connected to numbers 7 and 8 on terminal strip C2. The set point temperature of the storage tank is adjustable (default set at 60°C, the flow temperature is DHW setpoint + 20K). Warning: if a CH heat demand exists immediately after finishing the heat request for DHW, it is possible for high temperatures to flow into the CH system regardless of CH set point (hot shot).

4.3.3 General behaviour with external storage tank (DHW priority)

Disabling warm water operation: press Summer-Winter button R2-C4(not active in main screen). See later in manual for further explanation.

Enabling warm water operation: press Summer-Winter button R2-C4(active in main screen). See later in manual for further explanation.

In the default boiler configuration, meaning 2 pumps (DHW and CH pump), a DHW request has priority over CH request.

In the technician menu, advanced DHW settings, DHW priority, the DHW priority over CH can either be disabled or a maximum DHW priority time may be set.

In case the DHW priority is disabled and both demands are active at the same, both pumps (CH and DHW) will be activated. During this time the flow temperature is set to either 80 °C (thermostat) or DHW setpoint + 20K (NTC sensor).

Notice: At outputs ≥ 40 kW double separation between exchanging media is required.

4.4 Cascade

For cascade application see document 0660460 Appendix B: Cascade

5 BOILER CONTROL

5.1 Control Panel

The control panel has 12 buttons and a display as shown in the figure below.

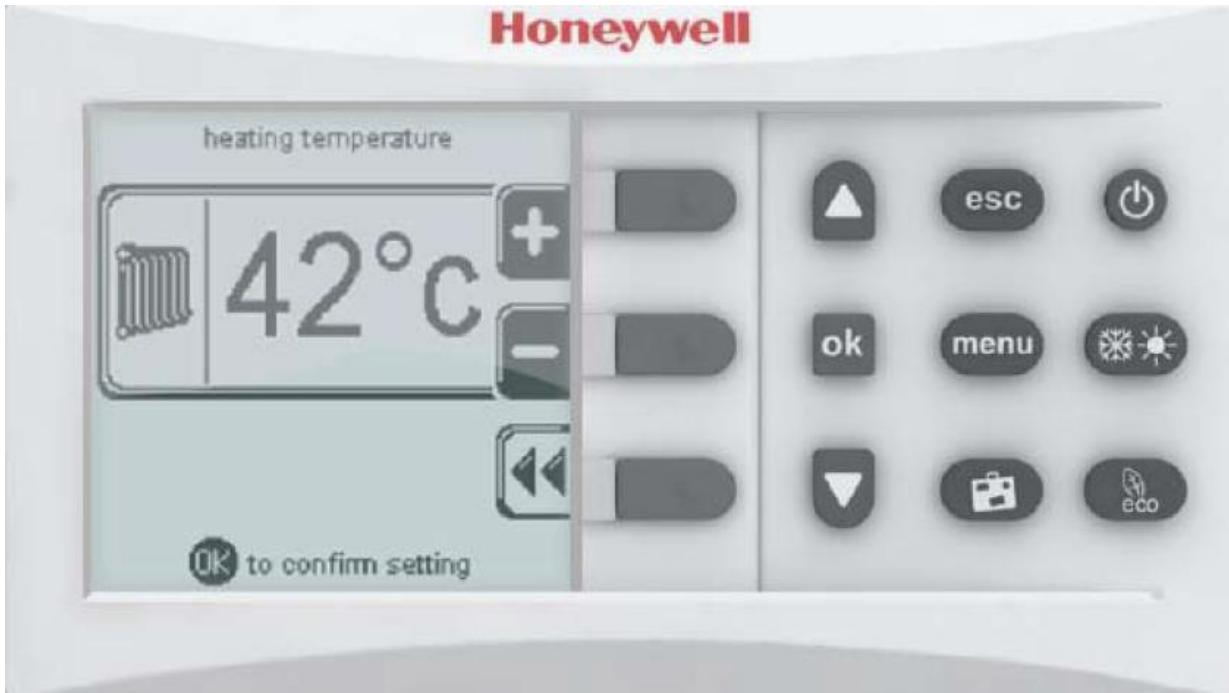

EN

5.2 Push buttons on control panel

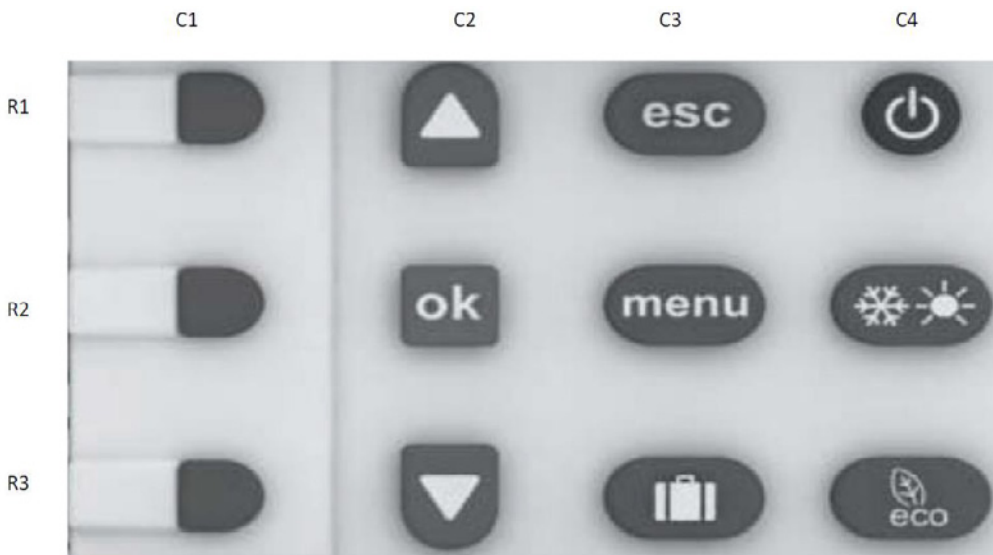

- R1-C1, R2-C1 and R3-C1 (back) buttons follow, if pressed, the associated icon in the display (left)
- R1-C2 and R3-C2 (up-down) buttons, scroll, if pressed, through the different menus
- R2-C2 button confirms, if pressed, the highlighted selection, or confirms what is required by LCD
- R1-C3 button (escape) returns, if pressed to main screen
- R1-C4 (on-off) button puts boiler in off mode, main logo and date/time stay displayed
- R2-C3 (menu) button enables if pressed, access to both user and installer menu
- R2-C4 (summer-winter) button enables-disables, if pressed, CH and DHW in main screens
- R3-C3 (holiday) button enables, if pressed, holiday function in main screens
- R3-C4 (eco) enables, if pressed, eco function in main screens

5.3 User menu

By pressing the “menu-button” the display will show the text as given in the figure below.

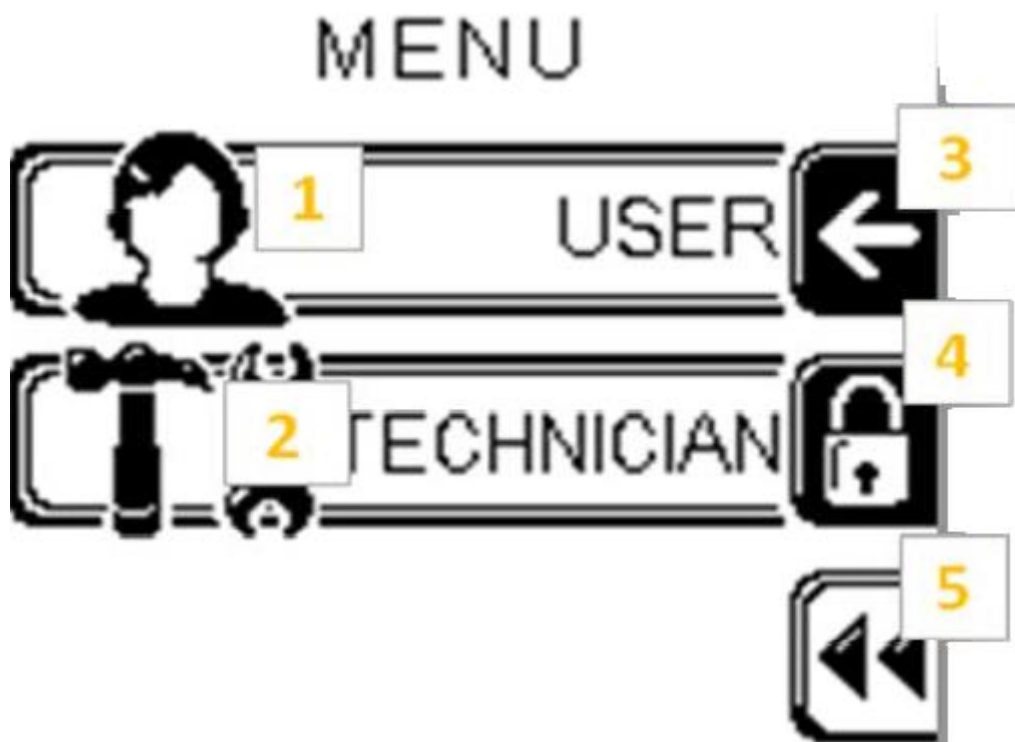

By pressing the button right to “3” (R1-C1 see 5.2) the user menu is accessed.

Pressing the button right to “5” (R3-C1 see 5.2) returns to the main screen.

By pressing the button right to “4” (R1-C2 see 5.2) the installer menu is accessed.

In the user menu the following possibilities will be shown:

1. HEATING
2. DOMESTIC HOT WATER
3. HOLIDAY
4. MAINTENANCE
5. SETTINGS
6. CHIMNEY-SWEEPER
7. DIAGNOSTICS

By pressing up and down (R1-C2 and R3-C2) 1 of the 7 options as shown above will be highlighted. By pressing the ok button (R2-C2) the chosen option will be confirmed. Once an option has been selected it is possible to change the parameters corresponding with the chosen option.

5.3.1 Parameter/value setting

Pressing the up and down (R1-C2 and R3-C2) buttons will highlight the desired parameter. Pressing the OK button (R2-C2) will allow the chosen parameter to be modified.

The figure as shown on the next page will appear

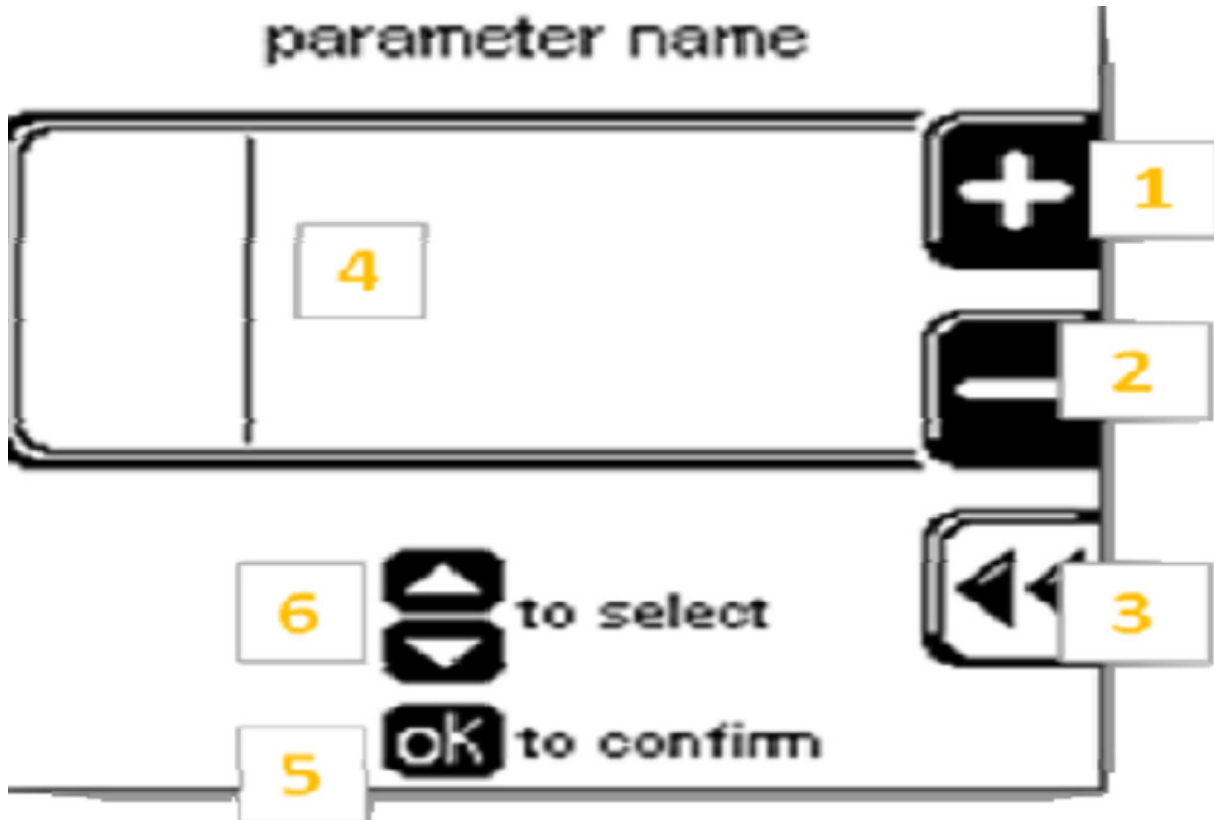

The actual value can be changed by pressing the R1-C1 and R2-C1 buttons. The changed value can be confirmed by pressing the ok (R2-C2) button. Pressing the back (R3-C1) button leaves the actual displayed parameter. If there are more parameters shown in the parameter value area (4) the desired parameter can be selected by pressing the up and down ((R1-C2 and R3-C2) buttons.

5.3.2 Parameters accessible by user

An overview of the parameters accessible by the user is given on the next page.

User menu	Submenu 1	Submenu 2	Submenu 3	Notes
1. HEATING				
	1. CH temperature/OTC set			Heating user settings Set the CH temperatures and OTC curves parameters
		1. CH setpoint		Adjust setpoint of CH circuit
		2. Outside temperature for CH off		Set the external temperature at which heat demand is removed. If set OFF, heat demand will be removed by controller (only by removing RT or bridge between terminal strip C2:1,2).
	2. Eco setpoint reduction			Set the temperature that will be subtracted from actual setpoint when ECO mode is activated
	3. Scheduler set			Invoke scheduler menu
		1. Enable/disable on board scheduler		Based on selection is possible to enable/disable on board scheduler
			Enable	Enable on board scheduler
			Disable	Disable on board scheduler
		2. Scheduler set		Select to set scheduler
			1 Monday	Used to program on board scheduler (ON, OFF, Eco)
			2 Tuesday	
			3 Wednesday	
			4 Thursday	
			5 Friday	
			6 Saturday	
			7 Sunday	
			8 Monday - Friday	
			9 Monday - Sunday	
			10 Saturday - Sunday	
2. DOMESTIC HOT WATER				
	1. DHW setpoint			Domestic hot water user settings
				Set the DHW temperature (in case of a DHW with sensor this is the actual DHW temperature, in case of DHW with thermostat this is the base boiler flow temperature)
	2. Eco setpoint reduction			Set the temperature that will be subtracted from actual setpoint when ECO mode is activated
	3. Scheduler set			Invoke scheduler menu
		1. Enable/disable on board scheduler		Based on selection possible to enable/disable DHW on board scheduler
			Enable	Enable on board scheduler
			Disable	Disable on board scheduler
		2. Scheduler set		Select to set scheduler
			1 Monday	Used to program on board scheduler (ON, OFF, Eco)
			2 Tuesday	
			3 Wednesday	
			4 Thursday	
			5 Friday	
			6 Saturday	
			7 Sunday	
			8 Monday - Friday	
			9 Monday - Sunday	
			10 Saturday - Sunday	
3. HOLIDAY				
	1. CH holiday setpoint			Holiday temperature settings Set CH flow temperature used when Holiday active

User menu	Submenu 1	Submenu 2	Submenu 3	Notes
	Submenu 1 2. DHW setpoint		Submenu 3	Set DHW temperature used during holiday mode
4. MAINTENANCE				Set maintenance related info
	1. Service information			Used to display service company phone number or entered info
	2. Service due date			Show next service due date. When date expired a MSG is shown on lower part of main screen asking for service.
5. SETTINGS				Boiler option settings
	1. Select language			Allow selection of different language
		English		Select for English
		Italian		Select for Italian
		German		Select for German
		Russian		Select for Russian
		Spanish		Select for Spanish
	2. Select units			Allow selection of different unit
		Fahrenheit		Select for Fahrenheit
		Celsius		Select for Celsius
	3. Set date			Allow RTC date setting
	4. Set time			Allow RTC time set. When selected a screen asking for time format 24/12hours is opened. When selected appropriate format screen jumps to time entering screen
		24 hours		Select for 24 hours clock
		12 hours		Select for 12 hours clock
6. CHIMNEY SWEEPER				Manual mode. Hitting OK will force boiler to operate at % of power. Timeout 15 minutes. While test in progress navigating through other menus allowed.
7. DIAGNOSTICS				Displays boiler usage information and errors
	1. Boiler information			Will display the information shown in Submenu 2. When the line has a * at the end of the line means that hitting OK when the line is highlighted will open a graph that shows the latest 120 variable values stored every 12 minutes (24 hour history).
		1 CH request 2 DHW demand 3 Firing rate 4 Flame ionization current 5 Boiler set point 6 Boiler supply temperature 7 Return temperature 8 Flue temperature 9 Outdoor temperature 10 DHW storage temp 11 Boiler fan speed 12 CH ignitions 13 CH runtime 14 DHW ignitions 15 DHW runtime 16 System pressure 17 Heat exchanger temp. 18 0-10V input 19 Target power		
	2. Lockout history			Shows a list of recent errors. Hitting OK on the highlighted error will open screens that contain details on boiler status when error occurred.

5.4 Installer (technician) menu

If the button (R2-C1) right to “4” (see figure above is) is pressed the screen as given in the figure below will appear.

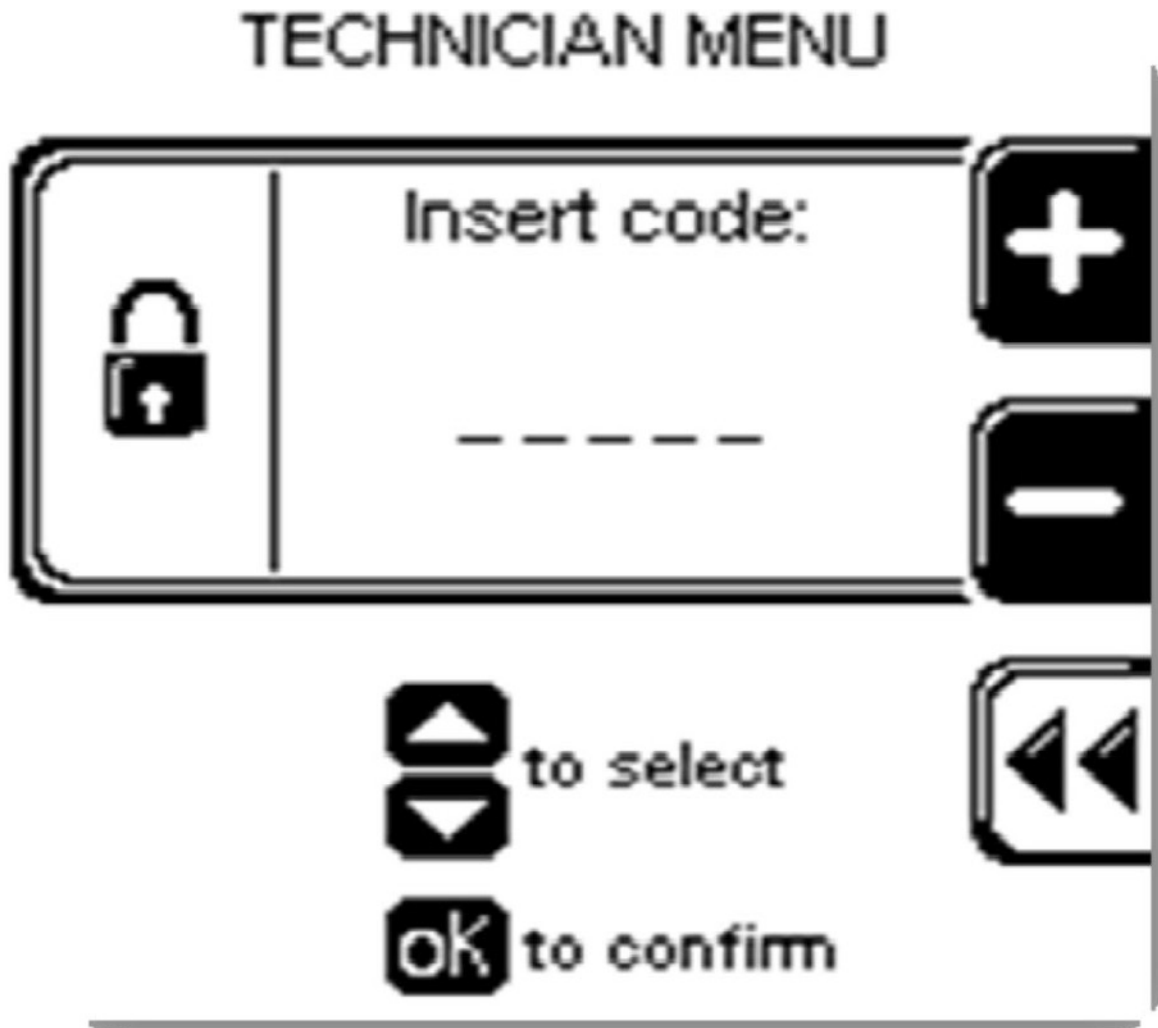

The installer (Technician) access code is 231

+ (R1-C1 and (R2-C1) buttons are used to increment/decrement value

Up and down (R1-C3 and R3-C2) buttons are used to select character to be modified OK (R2-C2) buttons confirms value

Once the menu is accessed by entering the code the following possibilities will be shown:

1. ADVANCED CH SETTINGS
2. ADVANCED DHW SETTINGS
3. SYSTEM SETTINGS
4. DIAGNOSTICS
5. USER SETTINGS
6. CASCADE
7. RESTORE FACTORY SETTINGS

By pressing up and down (R1-C2 and R3-C2) 1 of the 7 options as shown above will be highlighted. By pressing the ok button (R2-C2) the chosen option will be confirmed.

By pressing up and down (R1-C2 and R3-C2) 1 of the 6 options as shown above will be highlighted. By pressing the ok button (R2-C2) the chosen option will be confirmed. Once an option has been chosen it is possible to change the parameters corresponding with the chosen option.

See 5.3.1 for procedure of parameter change/setting.

5.4.1 Parameters accessible by installer (technician)

An overview of the parameters accessible by the installer (technician) is given on the next pages.

Technician menu	Submenu 1	Submenu 2	Submenu 3	Submenu 4	Notes
1. Advanced CH setting					Heating installer advanced settings
	1. CH power set				Set power of boiler in CH mode
		1. Maximum power			Set % of boiler maximum power in CH mode
		2. Minimum power			Set % of boiler minimum power in CH mode
	2. CH temperatures				Set (selecting OK) and show CH temperatures
		1. Absolute max temperature			Set absolute CH max temperature (CH setpoint is limited by this parameter)
		2. CH maximum setpoint			Determine higher boundary of CH setpoint
		3. CH minimum setpoint			Determine lower boundary of CH setpoint
		4. CH setpoint hysteresys			Sets CH setpoint hysteresys (temperature above setpoint at which boiler will switch off)
	3. OTC parameters				Set OTC parameters
		1. Outside temperature for max CH			Define external temperature at which OTC will set maximum CH setpoint
		2. Outside temperature for min CH			Define external temperature at which OTC will set minimum CH setpoint
		3. Outside temperature for CH off			Set the external temperature at which heat demand is removed. If set OFF heat demand will never be removed by controller (Only by removing RT or bridge between terminal strip C2:1,2)
		4. OTC setpoint table			Show in a table the link between external temperature and actual setpoint determined by OTC parameter selection
		5. OTC curve			Show in a curve the link between external temperature and actual setpoint determined by the OTC parameter selection
	4. CH pump settings				Set pump usage related parameters
		1. Post pump time			Set the CH pump overrun time
	5. CH Anti cycling timer				Set the anti cycling timer (minimum time between boiler goes off till next ignition)
	6. CH request type				Allow selection of different CH requests:
		Only OTC			Select OTC: outdoor Temperature controller
		Room Tstat			Select RT/OT: Room Thermostat or OpenTherm
		0-10V Signal [%]			Select 0-10Vdc input for Power mode
		0-10V Signal [SP]			Select 0-10Vdc input for setpoint mode
2. Advanced DHW setting					Domestic hot water advanced settings
	1. DHW power				Set power of boiler in DHW mode
		1. Maximum power			Set % of boiler maximum power in DHW mode
		2. Minimum power			Set % of boiler minimum power in DHW mode
	2. DHW temperatures				Set (selecting OK) and show DHW temperatures
		1. Storage temperature setpoint			Set flow temperature during DHW mode when DHW done via a thermostat (switch)
		2. Boiler temperature setpoint			Set DHW temperature setpoint when DHW done with temperature sensor

		3. DHW setpoint hysteresis				Set DHW setpoint hysteresis (temperature below setpoint at which the boiler will be switched on)
3. DHW pump settings						Define pump usage in DHW mode.
4. DHW priority		1. DHW post pump time				Set the DHW pump overrun time added to the prefixed time of 3 minutes
		1. DHW priority status				Define DHW priority over CH
				Enable		Enable/disable DHW priority over CH
				Disable		Enable
		2. DHW priority timeout				Disable
						Define after how much time DHW priority is ended (CH can be served if present for the same amount of time)
				Off		Select for no timeout (While DHW priority status is enabled)
				minutes		Select for no timeout (While DHW priority status is enabled)
5. DHW request type						Set timeout in minutes (While DHW priority status is enabled)
		Switch				Define DHW request switch or sensor
		Sensor				DHW starts when switch (thermostat) closes
						DHW starts based on required vs actual DHW temperature
						Boiler and system parameters
3. SYSTEM SETTINGS						
1. Boiler parameters						Boiler related parameters
		1. Ignition power				Set power % used when igniting burner
		2. Delay siphon check				Delay time to validate a syphon error
		3. Number of boiler pump				Define pump and 3-way valve or 2 pumps
				Pump and 3WayValve		System with pump and 3-way valve
				Two pumps		
		4. Pump speed max				System with 2 pumps (DHW and CH)
		5. Pump speed min				Maximum % of PWM pump speed
		6. Antilegionella				Minimum % of PWM pump speed
						Based on selection possible to enable/disable Antilegionella protection
				Enabled		Enable Antilegionella protection
				Disabled		Disable Antilegionella protection
		7. Modbus parameters				Set Modbus parameters
				Address		Set address default: I
				Baudrate		Set baudrate default: 38400 bps
				Frame		Set frame 8NI
		8. 3 Way valve travel time				Select for setting travel time 3WV in seconds. Only for electric valve not hydraulic valve. Type of valve is an OEM setting cannot be changed.
						Set travel time 3Wv (DHW <- -> CH)
				Seconds		Allow selection of a different language
2. User interface settings		1. Select language				
				English		Select for English
				Italian		Select for Italian
				German		Select for German

			2. Outside temperature for CH off		Set the external temperature at which Heat demand is removed.
	2. ECO set point reduction				Set the temperature that will be subtracted from the actual setpoint when ECO mode is activated.
	3. Scheduler set				Invoke scheduler menu
			1. Enable/disable on board scheduler		Based on selection is possible to enable/disable on board scheduler
				Enable	Enable on board scheduler
				Disable	Disable on board scheduler
			2. Scheduler set		Select to set scheduler
				1 Monday 2 Tuesday 3 Wednesday 4 Thursday 5 Friday 6 Saturday 7 Sunday 8 Monday - 9 Friday 10 Monday - 10 Saturday - Sunday	Used to program on board scheduler
2. Domestic hot water					Domestic hot water user settings
	1. DHW set point				Set the DHW temperature (in case of a DHW with sensor this is the actual DHW temperature, in case of DHW with thermostat this is the base boiler flow temperature)
	2. ECO set point reduction				Invoke scheduler menu
	3. Scheduler set				Invoke scheduler menu
			1. Enable/disable on board scheduler		Based on selection is possible to enable/disable on board scheduler
				Enable	Enable on board scheduler
				Disable	Disable on board scheduler
			2. Scheduler set		Select to set scheduler

5.5 Manual Chimney sweep mode

For routine maintenance and/or service intervention a CH request can be generated to force the burner to a specific load from minimum to nominal (0-100%). This is only possible if no error condition is present. The chimney sweep function can be started from the user menu and will be active for 15 minutes. While active it is possible to navigate through other menus to check the boiler status and functionality.

5.6 Disabling CH request

The CH function can be disabled. See 5.3.2 parameters accessible by user at 1 HEATING nr 3 scheduler set.

5.7 Service code

To access the service-level of the controller it is necessary to enter the service-code. How this done is explained in 5.4 installer (technician) menu.

5.8 Tacho fan speed

For service purposes it is possible to read the fanspeed.

See 5.4.1 parameters accessible by installer (technician) at 4 DIAGNOSTICS nr 1 boiler information.

5.9 Errors

For service purposes it is possible to see a list of recent errors. See 5.3.2 parameters accessible by user at 6 DIAGNOSTICS nr error history.

5.10 ECO working mode

When the ECO button (R3-C4) is pressed a programmable value (see user menu 1. HEATING under 2 ECO Set Point Reduction) is automatically subtracted from the flow temperature setpoint, weather compensated (OTC) setpoint, or 0-10V setpoint.

The same principle is applicable for DHW (see user menu 2. DOMESTIC HOT WATER under 2 ECO Set Point Reduction)

5.11 Holiday mode

When the Holiday button (R3-C3) is pressed a request is indicated to enter the start and end date of the holiday period. The desired flow temperature and the DHW temperature for this period can be set (see user menu 3. HOLIDAY under 1 and 2)

5.12 Schedulers CH and DHW

For CH and DHW separate schedules can be set. Both schedules are set to enabled and always on by default. Scheduler set (ON, ECO, OFF) can be done for each day, for a group of weekdays, for weekend days or for an entire week. The status of the scheduler is set on the main screen (ON, ECO, OFF).

The scheduler can be set in the user menu, heating or domestic hot water or in the technician menu, user settings, heating or domestic hot water. Eco mode can also be forced by pushing the ECO button on the control panel (R3-C4).

5.13 Cascade and Modbus

Cascade and Modbus options are shown in two separate documents:

For Modbus see document 0660450 Appendix A: Modbus

For Cascade application see document 0660460 Appendix B: Cascade

5.14 Parameter settings

The parameter settings are listed on the following pages

Notice

The following parameters in the technician menu have restrictions:

Technician menu ----> 1 advanced settings ----> 2 CH temperatures ----> 1 absolute max. temperature

Setting higher than 90 degrees is not allowed

Technician menu ----> 3 system settings ----> 1 boiler parameters- ----> 2 delay siphon check

This setting must have a value between 1 and 5

Technician menu ----> 3 system settings ----> 1 boiler parameters ----> 1 ignition power

The setting of 20 % must not be changed

If instructions as written above are not followed Mark Climate Technology cannot be held responsible for eventual consequences

USER MENU					
			Recommended	Min	Max
1. HEATING	1. CH Temperature / OTC set	1. CH setpoint	85	20	90/Technician
		2. Outside temperature for CH off	OFF	7	30
	2. ECO setpoint reduction		50	0	50
	3. Scheduler set	1. Enable/disable on board scheduler	Enabled	Disabled	Enabled
		2. Scheduler set	ON	ON/OFF	ECO
2. DOMESTIC HOT WATER	1. DHW setpoint (switch)		80	35	85
	1. DHW setpoint (NTC sensor)		60	10	65
	2. ECO setpoint reduction		20	0	50
	3. Scheduler set	1. Enable/disable on board scheduler	Enabled	Disabled	Enabled
		2. Scheduler set	ON	ON/OFF	ECO
3. HOLIDAY	1. CH holiday setpoint		20	20	90/Technician
	2. DHW holiday setpoint (Thermostated)		80	35	85
	2. DHW holiday setpoint (NTC sensor)		60	10	65
4. MAINTENANCE	1. Service information		Service tel. set by Technician		
	2. Service due date		Date set by Technician		
5. SETTINGS	1. Select language		English	English/Italian	German/Russian
	2. Select units		Celsius	Fahrenheit	Celsius
	3. Set date		set date		
	4. Set time		24 hours	24 hours	12 hours
6. CHIMNEY SWEEPER			OFF	0	100
7. DIAGNOSTICS	1. Boiler information		Real time boiler status		
	2. Lockout history	Overview lockout history	Status boiler at time of lock/block		

EN

TECHNICIAN MENU							
			Recom- mended	Min	Max	After factory reset	
1. ADVANCED CH SETTINGS	1. CH power set	1. Maximum power	100	0	100	100	
		2. Minimum power	0	0	100	0	
	2. CH temperatures	1. Absolute max. temperature		90	20	90	80
		HIGHER THAN 90 NOT ALLOWED					
		2. CH maximum setpoint		85	20	Abs. max CH temp	75
		3. CH minimum setpoint		20	20	70	40
	4. CH setpoint hysteresis		5	2	10	3	
	3. OTC parameters	1. Outside temp for max CH		-10	-34	10	-10
		2. Outside temp for min CH		18	15	25	18
		3. Outside temp for CH off		OFF	7	30	OFF
		4. OTC setpoint table		OTC table			
5. OTC curve		OTC curve					
4. CH pump settings	1. Post pump time		10	1	30	5	
5. CH anticycling timer			3	0	15		
6. CH request type			RT+SP/OT	onlyOTC/RT	01-Vdc% / SP	RT+SP/OT	
2. ADVANCED DHW SETTINGS	1. DHW power	1. Maximum power	100	0	100	100	
		2. Minimum power	0	0	100	0	
	2. DHW temperatures	1. Storage temperature setpoint		80	35	85	80
		2. Boiler temperature setpoint		60	35	65	60
		3. DHW setpoint hysteresis		6	2	10	3
	3. DHW pump settings	1. DHW post time		1	OFF	180	30
	4. DHW priority	1. DHW priority Status		Enabled	Enabled	Disabled	Enabled
		2. DHW priority TimeOut		Off	1	60	Off
5. DHW request type			Switch	Switch	Sensor	Switch	

TECHNICIAN MENU								
				Recom- mended	Min	Max	After factory reset	
3. SYSTEM SETTINGS	1. Boiler parameters	1. Ignition power		20	0	100		
		HIGHER THAN 30% NOT ALLOWED						
		2. Delay siphon check		3	0	20		
		CHECK SYPHON IS NOT EMPTIED BY NEW VALUE						
		3. Number of boiler pumps		2 pump	Pump 3-w-valve	2 pump	2 pump	
		4. PWM pump speed Max		100	I	100	100	
		5. PWM pump speed Min		40	I	100	30	
		6. Antilegionella		Enabled	Disabled	Enabled	Disabled	
	7. Modbus parameters		Adress	Baudrate	Frame			
	8. 3 Way valve travel time		180	I	255	10		
	2. User inter- face settings	1. Select language		English	English/Italian	German/Russian		
		2. Select units		Celsius	Fahrenheit	Celsius		
		3. Set date		Set date				
		4. Set time		24 hours	24 hours	12 hours		
	3. Service settings	1. Service information		Set telephone number				
		2. Service due date		Set service date				
	4. DIAGNOSTICS	1. Boiler information		Real time boiler status				
2. Lockout history		Overview lockout history		Status boiler at time of lock/block				
3. Manual test		See chimney sweeper						
5. USER SETTINGS	0. Heating	1. CH temperature/ OTC set	1. CH set point	85	20	90/abs max CH temp	75	
			2. Outside tempe- rature for CH off	off	7	25	off	
		2. ECO setpoint reduction		50	0	50		
		3. Scheduler set	1. Enable/disable on board scheduler		Enabled	Disabled	Enabled	
			2. Scheduler set		Set time scheduler (Time/On/ECO/Off)			
	2. Domestic hot water	1. DHW setpoint (NTC sensor)		60	35	65		
		1. DHW setpoint (Thermostated)		80	35	85		
		2. ECO setpoint reduction		20	0	50		
		3. Scheduler set	1. Enable/disable on board scheduler		Eabled	Disabled	Enabled	
			2. Scheduler set		Set time scheduler (Time/On/ECO/Off)			
	3. Holiday	1. CH Holiday setpoint		20	20	90/abs max CH temp		
		1. DHW holiday setpoint (Thermostated)		80	35	85		
		2. DHW holiday setpoint (Sensor)		60	10	65		
6. CASCADE	1. Cascade set	1. Cascade switch delay		30	0	255		
		2. Cascade min power		20	0	100		
		3. Burner power (default value x=17,21,25,29 boiler specific)		x	0	2550		
		4. Boiler for DHW		0	I	6	0	
		5. PI loop period		5	0	15	5	
		6. Burner water flow delay		30	0	255	30	
		7. Different boiler size		Disabled	Disabled	Enabled	Disabled	
		8. Cascade pump speed mx		100	15	100	100	
		9. Cascade pump speed min		40	15	100	30	
	2. Cascade info	1. Cascade Role : see Cascade auto detection		Standalone	Standalone	Master/Slave		
		2. System temperature		Actual temperature Cascade system sensor				
		3. Number of boilers on		Actual number of burners/boilers on in cascade				
		4. Modulation level		Actual cascade modulation level				
3. Cascade auto detect: Press OK to start detecting role boiler in cascade chain		Standalone	Standalone	Master/Slave				
7. RESTORE FACTORY SETTINGS				Reset to factory/check settings				

6 INSTALLATION

6.1 *Installing the boiler*

The installation must be done in accordance with all local and national codes, regulations and standards, and in accordance with the directives of all relevant authorities.

When installed and for the first-time operated fill in the date and data in the table in chapter 9.1

1. The boiler has to be installed in an area where it is allowed to install it. Make sure that this area is protected against the danger of freezing.
2. The area should have sufficient ventilation and cooling to prevent overheating.
3. When delivered the boiler is on a pallet. The frame is mounted on two u-profiles. You can put 2 straps from one side beneath the boiler to the other side. With these straps and a few persons you can lift the boiler from the pallet.
4. Install the boiler on a flat non-combustible floor and level it by using its positioning bolts.
5. A minimum free space of 50 cm should be left on each side of the boiler for servicing purposes.
6. Remove the sealing/protection caps from the connection tubes.
Warning: take care as residual water from testing may drip.
7. Fill the condensate trap with clean water.
This can be done by flushing some water into the cast aluminium exhaust connection on the back. This water will then drain into the sifon and fill it.

6.2 *Frost protection*

The boiler is protected against frost.

If the flow NTC senses a temperature lower than 8 °C the CH-pump will be activated. If temperatures keeps dropping the boiler will start at a flow temperature of 6 °C and it will run on minimum load till the flow NTC senses a temperature of 15 °C and the return NTC senses a temperature of 15 °C. The CH-pump will stay running for another 10 minutes. This is only a protection for the boiler and does not protect the installation and its radiators against freezing.

During longer periods of absence in the winter, the installation itself should be protected by activating the heating periodically and by partly opening the radiator valves. Where a room thermostat is controlling the demand, do not set the room thermostat to a value below 15 °C.

To protect frost sensitive radiators against frost it is possible to connect a frost thermostat in parallel with a Volt free room thermostat.

It is also possible to set the CH pump to activate automatically under OTC settings when an outdoor sensor is present (this must be set by the installer). In this case, the CH pump will be activated if the outdoor temperature drops below 8 °C.

6.3 Water connection

6.3.1 Pump

The boiler does not have a built in CH-pump. Therefore a CH-pump should be mounted into the installation. Select a pump that matches the hydraulic resistance of the boiler and the installation. In the graph below you'll find the resistance characteristics for all types.

Hydraulic pressure drop

EcoFlex 168-5,210-6,252-7,294-8

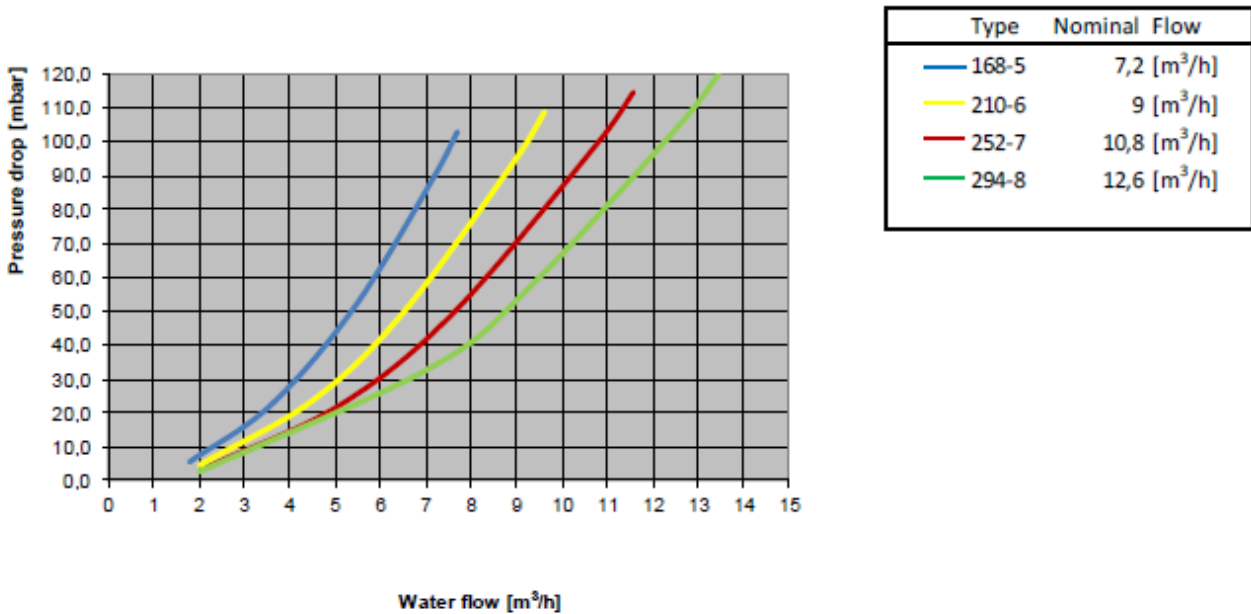

For electrical connections see chapter 6.7.

6.3.2 Minimum flow

The minimum flows as indicated in the table beneath should be guaranteed.

Type	Flow [m ³ /h] @ dT 25 full load	Flow [m ³ /h] @ dT30 Start = 20%	Flow [m ³ /h] @ dT30 part load
168-5	5,8	1,73	0,96
210-6	7,2	2,16	1,20
252-7	8,7	2,60	1,45
294-8	10,0	3,03	1,69

6.3.3 Water-treatment

Before filling up the installation (old and new), the installation should be rinsed thoroughly with clean water from the tap. There are some rinsing/cleaning products listed below and it is recommended that these are used.

- The water hardness of the heating system must be according the German VDI guideline 2035. See table beneath.



Water hardness in heating systems according VDI 2035 guidelines

< 0,11 °dH means demineralised °dH means German hardness	installation < 20 ltr/kW	installation between 20 and 50 ltr/kW	installation > 50 ltr/kW
50-300 kW total boiler capacity	< 11,2 °dH	< 8,4 °dH	< 0,11 °dH
300-600 kW total boiler capacity	< 8,4 °dH	< 0,11 °dH	< 0,11 °dH
> 600 kW total boiler capacity	< 0,11 °dH	< 0,11 °dH	< 0,11 °dH

For instance: For a EcoFlex 210 kW boiler and a total hardness of 11,2 °dH (German hardness) the total volume of filled, refilled and topped up water must not exceed 20 ltr/kW. If this hardness value is exceeded the total amount of filling, refilling and topping up water is: $(11,2/\text{actual hardness in } ^\circ\text{dH}) \times \text{ltrs/kW}$. In case of water hardness of 16 °dH the maximum volume/kW is $(11,2/16) \times 20 = 14 \text{ ltrs/kW}$. If higher values are present, the water should be softened. The water may only be partly softened to a value of 20 % of its original value. Example: if the initial hardness is 15 °dH, then it may only be softened to 3,0 °dH. Note that water softening by means of ion exchange principle is not allowed. If the installation is filled with demineralised or distilled water additives must be added to stabilise the pH value in order to prevent corrosion. Before filling with demineralised water, the complete installation must be rinsed.

- The pH must be kept between 7 and 8,5 at all times
- The maximum allowed content of chlorides is 150 mg/ltr
- The conductivity of the non treated installation water must not exceed the value of 300 µs/cm in combination with max O₂ of 0,1 mg/ltr. If the O₂ content is lower than 0,02 mg/ltr a higher conductivity limit of 600 µs/cm is allowed.
- If the conductivity is higher than the values mentioned, empty the system, flush and fill with clean tap water, preferably by adding the recommended cleaning products. Especially in low temperature heating systems normal degassing systems are insufficient. The use of an advanced system is required.
- Water pressure must be higher than 0,8 bar
- The water quality must be checked on a regular base (at least once every year)
- There are many products available on the market which pretend to clean and protect heating systems. Unfortunately there are only a few that have really proven this in practice. Therefore Mark Climate Technology only allows the following quality products for water treatment ;
 - Producer : Fernox, www.fernox.com
 - Cleaner F3 : removes corrosion, lime and sludge
 - Protector F1 : protects against corrosion, lime and sludge
 - Alphi-11 : anti-freeze and protection against corrosion and lime
 - Producer : Sentinel www.sentinelprotects.com
 - X100 : Inhibitor scale and corrosion protection
 - X200 : Noise reducer long life system treatment to eliminate noise
 - X300 : System cleaner for new hydronic heating systems
 - X400 : System restorer non acid cleaning of older systems
 - X500 : Inhibites antifreeze against scale and corrosion in all types of indirect heating systems at low temperatures

Note that these products must be used strictly in accordance with the water treatment manufacturers instructions.

Furthermore we strongly recommend the following ;

- Use the above mentioned water treatment protection products to fill and protect the installation
- Use a log book to record water filling, refilling, topping up, water quality measurements and water treatment
- Only use diffusion tight material, especially for under floor heating
- Always mount air vents at the highest points in the installation.
- Install isolation/check valves near the boiler and on strategic locations (anticipating any future expansions of the system) to avoid fills, refills and topping up as much as possible.
- Install a water meter to check the amount of filled, refilled and topped up water.
- Install a filter (magnetite and dirt) in the return.
- Install an isolation heat-exchanger to separate the boiler from the installation to protect dirt or lime in the secondary system from affecting the boiler.
- Avoid leaks and if there is a leak, repair as soon as possible.

6.3.4 *Water connection general*

1. Water connections for flow and return are size 2"
2. The installation must have a pressure relief valve (with a capacity higher than the boiler output), mounted in the flow as close as possible (within 50 cm to the threaded connection) to the heat exchanger and an expansion vessel. The capacity of this vessel should be sufficient for the installation.
3. To avoid blocking and non volatile lock-out of the boiler control it is recommended to install a bypass in the installation to guarantee the minimum flow through the boiler.
The bypass valve should be mounted as far away from the boiler as possible to have the biggest possible content of the bypass-circuit (also a big radiator without valves could be used).
4. Drain the condensate by a funnel and a stench-trap to the sewer.
5. At the highest point of the installation a de-airing device should be mounted.

6.4 **Gas connection**

1. The gas connection must be done in accordance with all local and national codes, regulations and standards, and in accordance with the directives of all relevant authorities.
2. The gas pipe of the boiler has connection R 1"
3. In order to avoid blockage of the gas valve, ensure that there is no dirt left in the gas pipework towards the boiler.
4. The highest allowable inlet pressure for the gas valve is 50 mbar.
5. Check the heat input of the boiler.

6.5 **Air-supply and flue-gas connection**

Air connection: All types have air connection \varnothing 110 mm

Flue gas connection: \varnothing 200 mm for all types

Allowed Appliance types:

Possibilities for air / flue system: B23 C(11)3 C13 C33 C53 C63

Note: C63 is not possible for Belgium.

If the inlet air contains dust or dirt one should install a filter or a leaf catcher in the air supply.
Contact your supplier.

6.5.1 B23

As standard the boiler is delivered as type B23 where the supply air is taken from the room where the boiler has been installed in.

A vertical terminal is recommended.

Roof terminals and extensions and/or condensate trap/collector must be obtained by M&G.

6.5.2 C13

The wall terminal with its expander and/or condensate trap/collector must be obtained by M&G.

For pressure drop calculation of appliance type C13 use the table for pressure drop per component and the table for total pressure drop calculation.

6.5.3 C33

Roof terminals and extensions and/or condensate trap/collector must be obtained by M&G.

For pressure drop calculation of appliance type C33 use the table for pressure drop per component and the table for total pressure drop calculation.

Terminals must be installed in the same pressure area (within a plane of 1m²).

6.5.4 C53

Roof and wall terminals and expanders and/or condensate trap/collector must be obtained by M&G.

For pressure drop calculation of appliance type C53 use the table for pressure drop per component and the table for total pressure drop calculation.

6.5.5 C63

C63 appliances may only be equipped with Gastec QA materials and terminals or according NEN 14989-2.

Note: When using a C63 type flue configuration, it is essential to ensure that C63 is allowed in the country where the boiler is installed.

It is recommended to use a full aluminium flue system. A PP (Temperature class T120) or stainless steel flue system can also be used (See TPW table below). In this case the condensate must be drained before it flows back into the aluminium parts of the boiler. Otherwise aggressive condensate from the non-aluminium flue system can corrode the aluminium parts of the boiler. A condensate trap/collector must be mounted just before entering the silencer(s) of the boiler (also see 6.6.1 general).

T-P-W Class	
Temperature range	T120
Pressure range	P1
Condensate resistance (W=wet / D=Dry)	W

The minimal combustion products temperature and mass flow rate and the CO₂ are given in the table below.

Type	Part load	Vol. Flue m ³ /h	Vol. Air m ³ /h	CO ₂ %	T fluegas °C	rho kg/m ³
168-5	33,6	43	38	9,1	30	1,12
210-6	42	54	47	9,1	30	1,12
252-7	50,4	65	57	9,1	30	1,12
294-8	58	75	65	9,1	30	1,12

The maximum allowed recirculation rate under wind conditions is 10 %.

Maximum allowable combustion air temperature 45 °C.

The tables below give an indication of maximum lengths (in mtrs) for parallel air supply and flue outlet pipes. Also the equivalent of pipe length in mtrs of bends 90 ° and 45 ° is given.

Type	Max. allowed pressure drop	Parallel Air/Fluegas ø110/ ø200	Parallel Air/Fluegas ø180/ ø180	Parallel Air/Fluegas ø150/ ø200	Parallel Air/Fluegas with air filter box ø150/ ø200	Parallel Air/Fluegas ø200/ ø200
168-5	150 Pa	13 m	112 m**	83 m**	63 m**	
210-6	150 Pa	9 m	75 m**	53 m**	37 m**	120 m**
252-7	150 Pa	6 m	45 m**	36 m**	24 m**	82 m**
294-8	150 Pa	4 m	33 m**	26 m**	16 m**	60 m**

(**): Maximum allowed draught is 120 Pa; this means that in case of vertical flue the maximum length is limited to 30 mtrs

Table below gives the equivalent of pipe length in meter of bend 90°, 45°

Equivalent of pipe length in meters				
Bend	Pipe diameter			
	ø200 mm	ø180 mm	ø150 mm	ø110 mm
Bend 90°	5,75	4,5	4	3,5
Bend 45°	3,75	2,5	1,7	1,5

Warning: Do not install the terminals for supply of combustion air and for the exhaust of combustion products on opposite walls of the building
Terminals must be installed in the same pressure area (within a plane of 1m²)

6.5.6 C(11)3

For C(11)3 see cascade application document 0660460 Appendix B: Cascade

6.5.7 Pressure drop calculations

Flue-outlet and air-supply calculations;

Total pressure drop available for flue-outlet and air-supply is given in the table below

Air connection: all types have air connection ø 110 mm

Flue gas connection: ø 200 mm for all types

Type Boiler	Total available Pressure drop In [Pa] for B23, C13, C33, C53, C63
168-5	150
210-6	150
252-7	150
294-8	150

For pressure drop calculation of appliance types B23, C13, C33 and C53 use the next two tables on the following pages

Pressure drop table per component

Boiler type								
	1	2	3	4	5	6	7	8
Component	168-5		210-6		252-7		294-8	
Pressure drop [Pa]	Flue gas [Pa]	Air [Pa]	Flue gas [Pa]	Air [Pa]	Flue gas [Pa]	Air [Pa]	Flue gas [Pa]	Air [Pa]
Pipe length 1m ø 200mm	0,4		0,7		1,0		1,4	
Pipe length 1m ø 150mm		1,4		2,1		3,1		4,2
Bend 90° ø 200mm	2,5		4,0		5,7		7,8	
Bend 90° ø 150mm		5,3		8,3		12,0		16,4
Bend 45° ø 200mm	1,7		2,6		3,7		5,1	
Bend 45° ø 150mm		2,3		3,5		5,1		6,9
Terminal C33 ø 200mm, ø 150mm	12,4		19,4		27,9		36,9	
Terminal C13 ø 200mm, ø 150mm	6,4		10,0		14,4		19,1	
Terminal B23 ø 200mm	3,7		5,8		8,4		11,1	
Terminal C53 ø 200mm, ø 150mm	3,7	12,2	5,8	19,0	8,4	27,4	11,1	36,3
Condensate trap ø 200mm T + Bend 90°	5,0		8,0		11,4		15,4	
Expander 110/150		0,7		1,0		1,5		2,1
Air filter		35		45		50		60

Note: Maximum allowed draught is 120 Pa, this means that in case of vertical flue the maximum length is limited to 30 mtrs.

Table for total pressure drop calculation

1	2	3	4	5	6	7	8
	Number Flue gas ø 200mm m	Number Air gas ø 150mm m	delta pressure component Fluegas	delta pressure component Air	Total pressure drop Fluegas out [Pa] (2*4)	Total pressure drop Air in [Pa] (3*5)	Total pressure drop Fluegas + air in [Pa] (6 + 7)
1 Meter Pipe							
Bend 90°							
Bend 45°							
Condensate trap							
Expander							
Terminal:							
Total delta pressure [Pa]							

How to use the table:

- Column 1 used material
- Column 2 total number of used material of column 1 for flue gas out
- Column 3 total number of used material of column 1 for air in
- Column 4 pressure drop from pressure drop table /component for flue gas components
- Column 5: pressure drop from pressure drop table /component for air components
Select the correct column for the selected boiler type
(168-5: 1,2 , 210-6: 3,4 , 210-7: 5,6 294-8: 7,8)
- Column 6 total pressure drop flue gas: multiply column 2 *4



- Column 7 total pressure drop air: multiply column 3 *5
- Column 8 total pressure drop flue gas and air: column 6 + 7
- Finally add all together column 8

Total pressure drop must be lower than 150 Pa.

If the combined inlet/outlet system exceeds the maximum allowed pressure, this will result in a decrease of more than 5% of heat input capacity. This is not allowed.

Components must be obtained from M&G

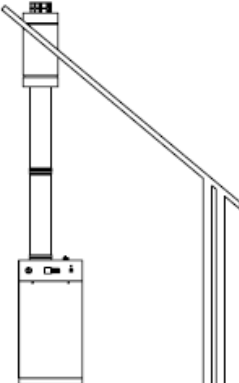
A list of allowed articles of M&G with corresponding OEM nrs is given on the next pages.

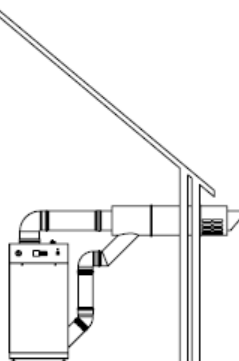
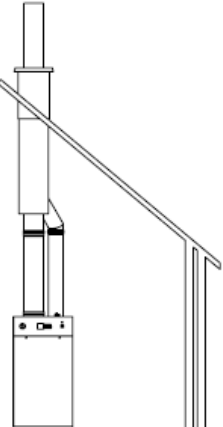
Appliance type	Fluegas outlet	Supply air inlet	
B23 	Roof terminal ALU 200 Or Roof terminal PP 200 7021	Leaf catcher ALU Expander I 10-150 EPDM	B23 
C13 	Wall Terminal ALU 200/200-200/300	Expander I 10-150 EPDM	
C33 	Roof Terminal ALU 200/200-200/300	Expander I 10-150 EPDM	

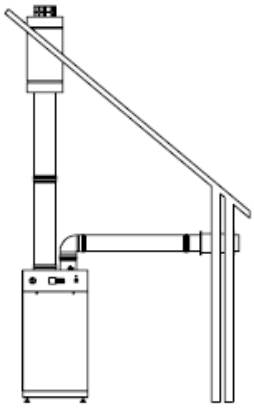
<p>C53</p> 	<p>Roofterm ALU 200</p> <p>Or</p> <p>Roofterm PP 200 7021</p>	<p>Wall Terminal air PP 150</p> <p>Expander I 110-150 EPDM</p>	
--	---	--	--

Components	OEM Art.no M&G
PP Ø 200 mm	
ELBOW PP 200 90° EPDM	41.007.04.11
ELBOW PP 200 45° EPDM	41.007.04.12
EXTENSION PP 200x500	41.007.04.01
EXTENSION PP 200x1000	41.007.04.02
EXTENSION PP 200x1900	41.007.04.04
ROOFTERM PP 200 7021	B23-C53 41.007.04.39
PP Ø 150 mm	
ELBOW PP 150 90°	41.007.03.31
ELBOW PP 150 45°	41.007.03.32
EXTENSION PP 150 x 2000	41.007.03.24
EXTENSION PP 150 x 1000	41.007.03.22
EXTENSION PP 150 x 500	41.007.03.21
EXPANDER EPDM Ø110- Ø150	41.008.56.32
LEAF CATCHER (AIR INLET GRILL) DN 150	41.007.54.36
WALLTERM PP 150 AIR C53	41.008.97.76
Aluminium	
ELBOW ALU 200 90°	41.008.05.40
ELBOW ALU 200 45°	41.008.05.41
EXTENSION ALU 200x1000	41.008.05.32
EXTENSION ALU 200x2000	41.008.05.33
EXTENSION ALU 200x500	41.008.05.31
ROOFTERM ALU 200	B23-C53 41.008.67.20
ROOFTERM ALU 200/200-200/300 C33	40.045.29.27
WALLTERM ALU 200/200-200/300 C13	41.002.78.30
General	
Wall Bracket 200	41.008.71.98
SEAL EPDM 200 (PP DN 200)	41.007.52.95
SEAL SIL 200 (ALU 200)	41.002.73.70
Wall Bracket 150	41.008.71.96
SEAL EPDM 150 mm (PP DN 150)	41.002.73.58
CONNECTION KIT PP DN 200	41.008.97.95
EXTENSION PP 200+ SAMPLING	41.007.04.06

Weather slate steep LEAD 210 25°-45° (for 41.007.04.39)	41.007.69.03
WEATHER SLATE FLAT ALU 210 0° (for 41.007.04.39)	41.007.96.12
WEATHER SLATE FLAT ALU 320 0° (for 40.045.29.27)	41.007.96.48
WEATHER SLATE STEEP LEAD 320 18°-62° (for 40.045.29.27) Mention "slope" when ordering	40.047.06.62 .. 40.047.06.70
WEATHER SLATE FLAT ALU 228 0° (for 41.008.67.20)	41.007.96.47
WEATHER SLATE STEEP LEAD 228 18°-62° (for 41.008.67.20) Mention "slope" when ordering	41.000.63.20 .. 41.000.63.28

6.5.8 DOP

All the prescribed articles (flue and air) must be installed in accordance with the following DOP's:

For aluminium: 0.1 (Dn 60-250) (rigid, single) (flue) T200 PI WVI LI0/II/13 I50 030

For PP: 0.8 (Dn 200), (rigid, single) (flue) TI20 PI WI/2 030 LI E U

The latest versions of these DOP's can be found on the M&G site: <https://www.mg-flues.com>: Download center - Certifications.

Follow the instructions as given in 06640490 Appendix C: Flue and air inlet manual.

6.6 Installing flue-exhaust and air inlet

6.6.1 General

- Do not use different materials for either flue way or air inlet
- Only the manufacturers of flue way and air inlet components as mentioned in this manual may be used
- Both systems (flue and air) should be mounted free of tension

Condensate, ice-free terminal, funnel and stench trap

- The boilers can produce flue gasses with very low temperatures, what leads to condensation in the flue pipes and flue terminal. Therefore one should always mount an ice free terminal.
- Drain the condensate via a tundish and an U-trap to the sewer.

Air inlet

- If PP material is used for the air inlet a minimum distance of 35 mm between flue way and air inlet should be respected.
- The minimum insert length of the sleeve, leaf catcher or pipe must be 40 mm.

Flue exhaust

- A horizontal flue way pipe must be installed with a fall of 3° (50 mm per mtr) downwards to the boiler to allow condensate to flow back in the sump or condensate collector.
- The minimum insert length into the sleeve and the minimum length of the pipe end for aluminium and stainless steel must be 40 mm.
- If PP is used pay attention to the expansion (elongation) of the PP due to rise in flue gas temperature.
- Insert the PP pipe into the sleeve and redraw over a length of 10 mm (10 mm for maximum pipe length of 2 mtr).
- After mounting the minimum insert length into the sleeve and the pipe end must be 40 mm.

Condensate trap/collector

- The condensate trap/collector must be either connected by a tube to a sifon that at least has the same height of water lock as the one that is delivered with the boiler or by a T-piece to the sifon as delivered with the boiler

6.6.2 Brackets, mounting

Air inlet

- The first bracket should be mounted 0.5 mtr away from the boiler
- Horizontal and non vertical pipes should be bracketed equally divided with a maximum distance of 1 mtr between the brackets
- Vertical pipes should be bracketed equally divided with a maximum distance of 2 mtrs between the brackets
- In case of a chimney shaft, first identify the air inlet. The end of the air inlet pipe should be at least 0.5 mtr above the shaft. The last component before entering the shaft should be fixated. If a bend is the last component also fixate the component before the bend.

Flue exhaust

- A bracket should be mounted to every component except for the case that the length of the pipe before and after the bend < 0.25 mtr. In this case mount the first bracket at a length of max 0.5 mtr away from the boiler
- Horizontal and non vertical pipes that have a distance between the fixing brackets > 1 mtr should be equipped with a non clamping (to allow very little movement) bracket in between
- Vertical pipes should be bracketed equally divided with a maximum distance of 2 mtrs between the brackets
- In case of a chimney shaft, first identify the flue outlet. Check if the used shaft pipes are damaged or blocked. The end of the flue way pipe should be at least 0.5 mtr above the shaft. The last component before entering the shaft should be fixated. If a bend is the last component also fixate the component before the bend.

All brackets must be obtained from M&G

6.6.3 Sealings and conjunctions

- Prevent incorrect or damaged of seals by shortening pipes squarely and by deburring after shortening.
- Conjunctions/connections in the flue way may not be screwed.
- In the air inlet only aluminium or stainless steel conjunctions/connections may be screwed. It is not allowed to screw PP conjunctions/connections.
- Do not use glue or foam like silicon or PUR.
- To assure soundness all components must be sealed.
- For smooth conjunction only use a soap solution (1% in water). Do not use oil, grease or (acid free) vaseline

Important notice

If instructions as written above are not followed and or the materials for air inlet and fluegas outlet as quoted above are not used Mark Climate Technology can not be held responsible for eventual consequences

6.7 Electrical connection

1. The electrical installation should be in accordance with national and local regulations.
2. As standard the boiler is configured for 230 VAC / 50 Hz
3. The terminal strip is accessible by opening the front cover behind which the control is mounted.
4. Means for disconnection must be incorporated in the fixed wiring in accordance with the wiring rules. As it is a stationary appliance without means for disconnection from the supply a contact separation in all poles that provide full disconnection under voltage category III must be provided. The minimum cross section of the supply wire is 3 x 1.0 mm² and must be connected to the

numbers, 0 (=PE), 1 (=L) and 2 (=N) of strip C1.

5. It is not allowed to change the internal wiring fitted by the manufacturer.
6. The enable connected to numbers 1 and 2 of the strip C2 must be Volt free. To select, select from the technician menu, advanced settings, CH request for Room Tstat. The 0-10V DC (Power or Setpoint mode) should be connected to the numbers 3 (=negative-) and 4 (=plus+) and a short wire loop should be placed between the numbers 1 and 2 of strip C2. To set from the technician menu, advanced CH settings, CH request select either 0-10V % (power mode) or 0-10V SP (setpoint mode). Digital communication (open Therm OT+ version 3.0) should be connected to the numbers 1 and 2 of the strip C2. Select from the technician menu, advanced CH settings, CH request for Room Tstat. For digital communication with EBV like RS30 or Theta an additional communication module is required. For the internal OTC (outdoor temperature controller) a 12 kohm at 25° C (see NTC table at 6.7.2) should be connected to the numbers 5 and 6 of strip C2 and a short wire loop should be placed between the numbers 1 and 2 of strip C2. To set from the technician menu, advanced CH settings, CH request, select only OTC.
7. If a storage tank is connected to the boiler, the tank thermostat (or the tank NTC) should be connected to the numbers 7 and 8 on the strip C2. Select from the technician menu, advanced DHW settings, DHW request type. Note that a tank NTC should be 12 kohm at 25 °C (see NTC table at 6.7.2.)
8. The CH system pump should be connected to the numbers 3 (=PE), 4 (=L), 5 (=N) on strip C1 if in use in combination with a 3-way valve. (also see chapter 4.3). A PWM pump should be connected to 14 (=PE), 12 (=L) and 13 (=N) on strip C1. The PWM signal should be connected to 14 (PWM signal) and 13 (PWM ground) on strip C2. From the technician menu, system settings, boiler parameters the max and min pump speed can be set.
9. The DHW pump (or 230 VAC 3-way valve) should be connected to 6 (=PE), 7 (=L), and 8 (=N) on strip C1. If a CH pump is used it should be connected to 11 (=PE), 9 (=L) and 10 (=N) on strip C1.
10. If the system pump, CH pump, PWM pump, DHW pump, alarm connection or the 3-way valve consumes more than 0,8 A, it needs to be switched by an auxiliary relay.
11. The alarm output on the numbers 17 and 18 on strip C1 is a potential free relay output (230 VAC), max 0,8 A). The cascade/system pump output on the numbers 19 and 20 on strip C1 is a potential free relay output (230 VAC, 0,8A).
12. The B-B (Burner Block) on the numbers 21 and 22 on strip C1 provides an external (remote) burner block (error 77). The external contact must be a potential free contact (230 VAC).
13. The SPS_B (Burner Block) on the numbers 11 and 12 on strip C2 provides also an external (remote) burner block (error 77). In this case the external contact must be potential free (24 VDC).
14. The B-L (Burner Lock) on the numbers 9 and 10 on strip C2 provides an external burner lock (error 3). The external contact must be a potential free contact (24 VDC).
15. The main-fuse (5,0 A) is near the on/off switch on the right side of the control panel.

General remarks:

Use the lowest tube on the right side to guide the low voltage connections from C2.

Use the two upper tubes on the right side to guide the 230V connections from C1.

Also see wiring diagram on next page.

6.7.1. Wiring diagram

BC	Burner control
D	Display
C1	Connector 230V
C2	Connector low voltage
CH-P	Central heating pump
DHW-P	Domestic hot water pump
PWM-P	Modulating pump
A-P	Appliance pump max 0,8A
HE	Heat exchanger
NTC1	Flow temperature sensor
NTC2	Return temperature sensor
NTC3	Domestic hot water sensor or switch
NTC4	Outside temperature sensor
NTC5	Flue gas temperature sensor
NTC6	Cascade sensor
WPS	Waterpressure sensor
APS	Air pressure switch
SPS	Siphon pressure switch
GPS	Gas pressure switch
GV	Gas valve
S	Switch on/off
3WV	3 way valve
OT-RT	Opentherm or room thermostat on/off
OTC	Outdoor temperature control 12K
F	Fuse
SPS-B	Siphon pressure switch block
B-L	Burner lock
A	Alarm potential free contact
C-P	Cascade pum potential free contact
B-B	Burner block
PE	Earth cable or connector
Fr	Frame
MP	Mounting plate
CP	Cover plate
FP	Front plate

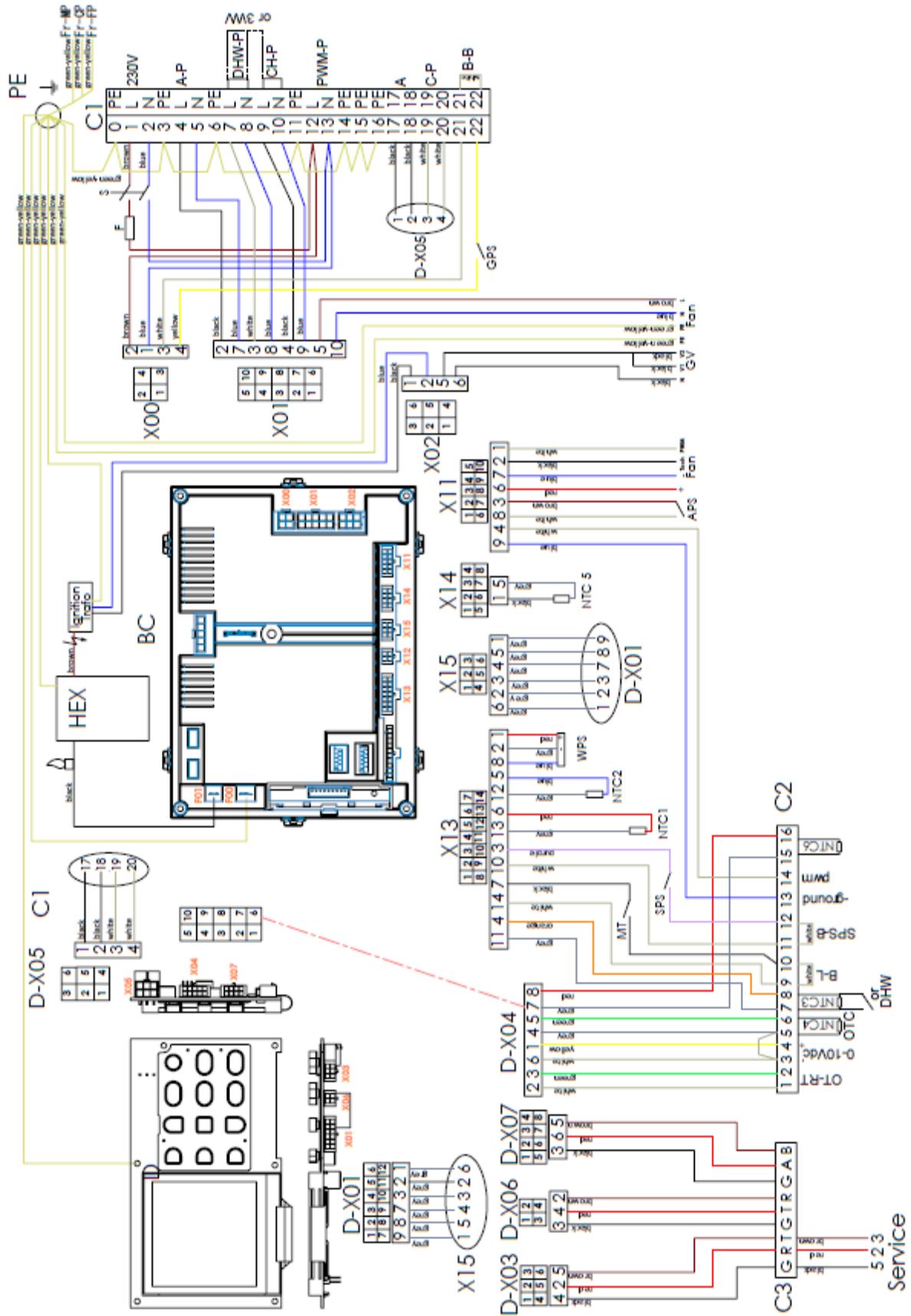

6.7.2 Table resistance NTC's

Temperature [°C]	Resistance [Ω]
	12K
-30	
-20	98.200
-15	75.900
-10	58.800
-5	45.900
0	36.100
5	28.600
10	22.800
15	18.300
20	14.700
25	12.000
30	9.800
35	8.050
40	6.650
45	5.520
50	4.610
55	3.860
60	3.250
65	2.750
70	2.340
75	1.940
80	1.710
85	1.470
90	1.260
95	1.100
100	950
105	
110	
115	
120	

6.8 Pneumatics connection

A pneumatic diagram for the EcoFlex 168 (5 sections) and the EcoFlex HR 294 (8 sections) is given in the figure below.

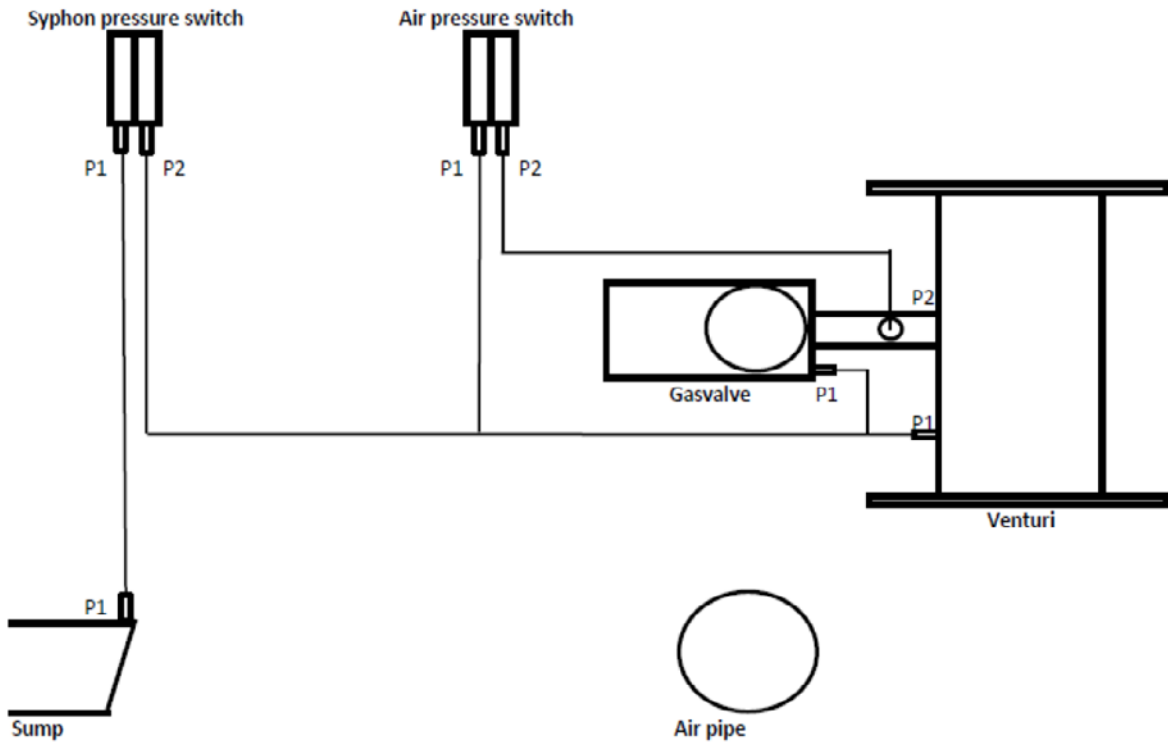

A pneumatic diagram for the EcoFlex HR 210 (6 sections) and the EcoFlex HR 252 (7 sections) is given in the figure below.

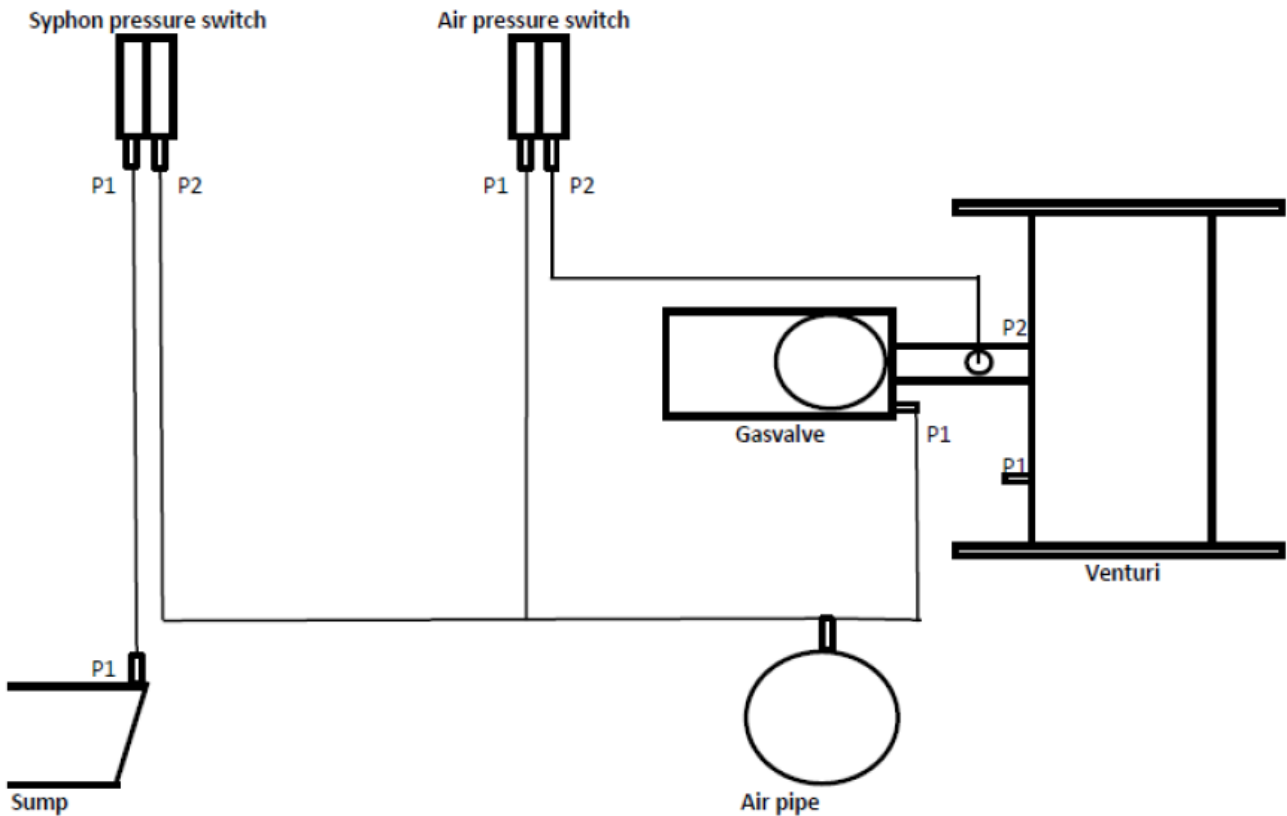

The siphon pressure switch, connected to the sump (P1), prevents overflow of the syphon in case of excess back pressure in the flue.

The air pressure switch, (P1 and P2), connected to the venturi, checks the amount of air (by means of a Δp measurement) before start.

6.8 PC-connection

For information regarding connection of a PC to the boiler you can contact your supplier.

EN

7 COMMISSIONING

1. Fill and bleed the installation. Fill the boiler until a pressure between 1.5 and 2 bar is achieved. The maximum working pressure is 6 bar. The boiler (not the installation!) is automatically bled by a built in automatic air vent.
2. Check all gas and water connections thoroughly for leaks.
3. Bleed the gas pipe.
4. As standard the boiler is set for G20, G25 or G25.3.
Check that the installation provides the right type of gas to the boiler.
5. Check the inlet pressure : 20 mbar or 25 mbar
6. Turn on the electrical boiler circuit by setting the mainswitch on the controlpanel of the boiler to position I (on).
7. Create a heat demand.
8. Just before ignition the control checks if the contacts of the gas pressure, siphon pressure and water pressure are closed.
If not, the boiler will block and the display will show E76.
9. If gas, water and siphon pressure are o.k. the burner will be ignited.
10. Have a thorough check on flue-gas joints for leakage.
11. Check the heat input and the gas pressure at maximum load.
12. Heat up the installation. Stop the heat demand.
13. Bleed the installation again, topping up the water system pressure if required.
14. Explain the functioning and operating of the boiler to the user.
15. Explain to the user the significance of error codes and the need to report them when requesting service engineer support.
16. After installation the datasheet as shown in chapter 9.1 should be filled in.
This has to be repeated at every service-interval.
17. Safely store the installation and the user manual preferably in close proximity to the boiler.

7.1 Gas category

The types of gas and supply pressures vary per country. In the table below the gas category and supply pressure are listed per country.

Country		Category	Pressure [mbar]
AT	Austria	I2H	20
BE	Belgium	I2E(R)	20/25
BG	Bulgaria	I2H	20
HR	Croatia	I2H	20
CY	Cyprus	I2H	20
CZ	Czech Republic	I2H	18
DE	Germany	I2ELL	20
DK	Denmark	I2H	20
EE	Estonia	I2H	20
ES	Spain	I2H	20
FI	Finland	I2H	20
FR	France	I2Esi, I2Er	20/25
GB	United Kingdom	I2H	20
GR	Greece	I2H	20
HU	Hungary	I2H	25
IE	Ireland	I2H	20
IT	Italy	I2H	20
LT	Lithuania	I2H	20
LU	Luxembourg	I2E	20
LV	Latvia	I2H	20
NL	Netherlands,the	I2L, I2EK	25
PL	Poland	I2E	20
PT	Portugal	I2H	20
RO	Romania	I2E, I2H	20
SE	Sweden	I2H	20
SL	Slovenia	I2H	20
SK	Slovakia	I2H	20
NO	Norway	I2H	20
CH	Switzerland	I2H	20
LI	Liechtenstein	I2H	20
IS	Iceland		
MT	Malta		

As the responsible manufacturer of my products, I'm aware that the above mentioned countries have adopted the Gas Appliance Directive 2009/142/EC in their national law.

I understand that the CE mark has meaning only in these countries, where the GAD is implemented in the national regulations.

Although other countries might value and respect the CE mark, it has no formal value.

This boiler can be adjusted for category K(I2K) and is in this case suitable for the use of G and G+ distribution gasses according to the specifications as shown in NTA 8837:2012 Annex D with Wobbe-index 43,46-45,3 MJ/m³ (dry, 0 °C, Hs) or 41,23 – 42,98 (dry, 15 °C, Hs).

This boiler can also be converted and re-adjusted for category E (I2E).

This means that the boiler either is suitable for G+ gas and H-gas or provable suitable is for G+ gas and provable can be made suitable for H-gas as meant by "Besluit van 10 Mei 2016" til changes in this document are made.

7.2 Adjustment % CO₂ and check on input

The boiler is equipped with an automatic gas/air regulator. This means that the amount of gas is regulated depending on the amount of air. The % CO₂ needs to be adjusted according to the table below.

Type of boiler	Gas type	Inlet pressure	%CO ₂ on max load	%CO ₂ on min load
168-5	G20 / G25 / G25.3	20 / 25 mbar	9,3 +0,2-0,05	9,1 +0,15-0,2
210-6	G20 / G25 / G25.3	20 / 25 mbar	9,3 +0,2-0,05	9,1 +0,15-0,2
252-7	G20 / G25 / G25.3	20 / 25 mbar	9,3 +0,2-0,05	9,1 +0,15-0,2
294-8	G20 / G25 / G25.3	20 / 25 mbar	9,3 +0,2-0,05	9,1 +0,15-0,2

The boiler has a gas valve that is connected to a venturi. See figure below:

Adjustment for max. load:

- Wait until the boiler is stable and measure % CO₂
- If required, correct CO₂ with the throttle ; turning to the right gives a lower CO₂ percentage (a 1/2 turn (180°) gives a change of approximately 0,2 % CO₂)

Adjustment for min. load:

- Wait until the boiler is stable
- If required, correct the CO₂ with the offset ; turning to the right gives a higher CO₂ percentage **Notice:** this offset adjustment is very sensitive : half a turn (180°) gives a change of approximately 1 % CO₂.

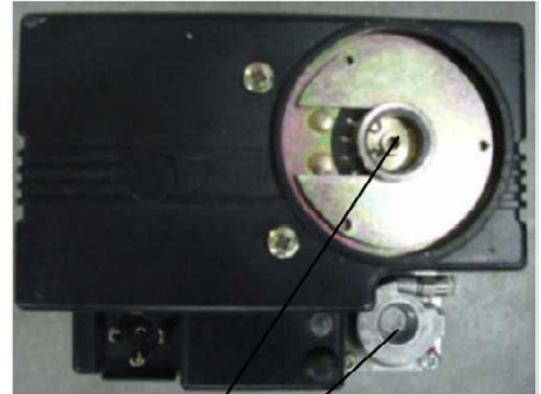

Throttle

Off-set

Check on heat input

In the table below the relationship between nominal input and rpm and gasflow is given. The nominal fanspeed can be ± 5% due to adjustments in production.

Nominal input	168	210	252	294	[kW Hi]
Fanspeed nominal	5300	5450	5850	5800	[rpm]
Gasflow G20	17,4	21,8	26,2	30,5	[m ³ /h]

If the gas flow is too low there is probably dirt (obstruction) in the air/flue system. Check and if necessary clean. The gas flow has to be checked again.

8 ERRORS

8.1 General

If there is no data visible on the display, the fuse (5,0 AT) in the controlpanel near the mainswitch should be checked (as well as the position of the on/off switch) and should if required be replaced (after the cause for break down has been determined and rectified).

WARNING: THIS FUSE IS PART OF THE 230 V CIRCUIT.
DISCONNECT THE BOILER FROM THE MAINS ELECTRICITY SUPPLY BEFORE REPLACING THE FUSE!

If there is still no data visible on the display, one has to check if there is 230VAC tension on the connections “L” and “N” of connector X00 in the MAXSYS. Also see electrical wiring diagram.

If there is 230VAC present (terminal connector C1: I2,I3) , then the 230V fuses F1 and F2 inside the Maxsys should be renewed. Disconnect the boiler from the main 230V supply and remove the connectors from the Maxsys.

Notice : for this it is not necessary to unscrew the Maxsys from the mounting plate

Release the six security clips with a long thin screw driver. Then remove the protective cover of the Maxsys. Replace the 230 V fuse(s) F1:T3.15 AL 250V and/or F2 T3.15 AL 250V inside the Maxsys.

A blown fuse in the Maxsys controller could be caused by a short-circuited pump. It is recommended to also check the CH-pump and DHW pump in this case.

If the 230 V fuses are o.k. and the display is still blank, then the cable of the display to the Maxsys (X15) should be checked. If this one is also ok, the Maxsys should be replaced.

six security clips



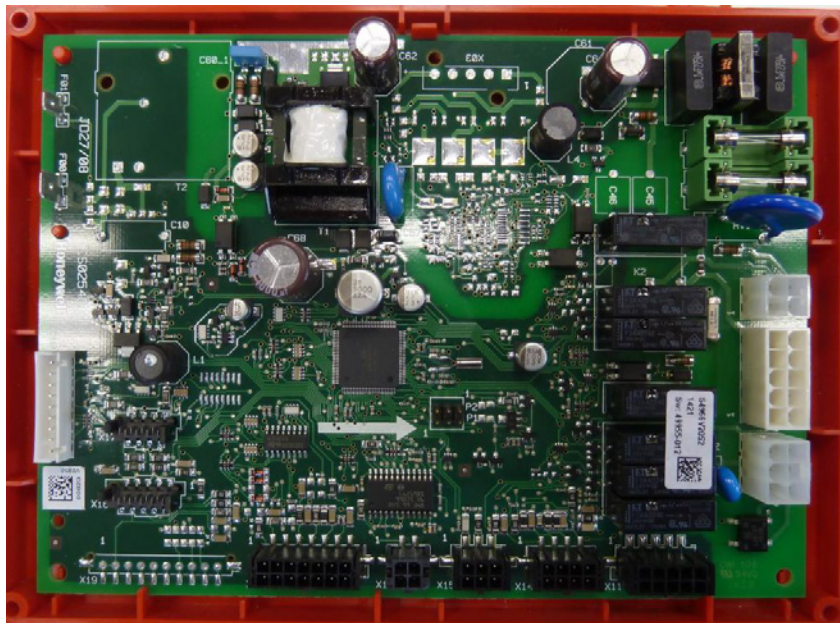

F1:T3.15A 250V

F2:T3.15A 250V

EN

If you are not sure there is any heat demand, you can force the boiler to start as described in 5.5.

At heat demand, the boiler control will perform zero-check of air pressure switch before starting the fan. After that the fan will start and wait for air pressure switch to close. As soon as APS has closed, starting procedure will continue.

APS closes at $\Delta P > 40$ Pa.

If there is a problem with APS, display will show blower speed error.

The boiler control checks the status of the built-in pressure switches for water, gas and siphon just before ignition.

Water pressure should be $> 1,4$ bar (E47)

Gas pressure should be > 14 mbar (E76)

Syphon pressure should be $< 8,3$ mbar (E77)

8.2 **DHW errors**

Boiler does not respond to DHW heat request

- Check the storage tank-NTC or thermostat and its wiring (also see electrical wiring diagram).
- Check if DHW is enabled using the control panel

Insufficient DHW flow

- Dirty filters in taps.
- Insufficient water pressure.

DHW temperature too low

- Tapping flow too high
- Setting of temperature too low
- Leakage 3-way valve (towards CH-circuit), 3-way valve not fully in DHW position
- Faulty DHW pump
- DHW operation set to off
- Storage tank-NTC or thermostat and or wiring defect.
- Input too low due to too much resistance in air/flue system.

Boiler operates only for DHW

- Storage tank-NTC or thermostat defect and or its wiring.
- 3-way valve defect (remains in direction towards storage tank)

8.3 **CH-errors**

CH circuit stays cold

- Incorrect connection to the mains electricity supply.
- Main switch on control panel is switched off (boiler off).
- Room thermostat defect, incorrect wiring, setting too low
- Outdoor sensor and/or its wiring defect.
- CH operation off
- 3-way valve defect (remains in direction towards storage tank)

8.4 **Errors (hard and soft lockouts)**

Errors are indicated by a text and an E-code on the bottom line on the display. Error message can be displayed by pressing the "information" button.

An error with a hard lockout. The boiler will not fire again until a manual reset is performed (e.g. max temp limit).

These errors can be found under column "hard lockout code" on the following page.

An error with a soft lockout. The boiler will automatically resume normal operation after the cause of block is solved (eg gas pressure too low). They can be found under column "soft lockout code" on the following page.

The cause of error (hard or soft lockout) can be found with the help of the error-list.

After the cause of error has been determined and the error has been solved, the boiler can be put back into operation again.

9 ANNUAL INSPECTION MAINTENANCE

Maintenance must only be done by a qualified installer or technician. The appliance must be inspected once every two years according to table 9.1.

Maintenance must be done once every two years according to table 9.1

The appliance is not to be used by children or persons with reduced physical, sensory or mental capabilities, or lack of experience and knowledge.

Children, even if being supervised, must not play with the appliance.

In the case of failure or malfunction of the appliance, do not attempt to repair it yourself.

Please contact your installer. Repairs must only be carried out by qualified technicians. Failure to comply with these requirements can compromise the safety of the appliance.

Inspection (also see 9.1, 9.2, 9.3 and 9.4)

Inspection set (article nr 0699074) must be used. Switch off the boiler. Disconnect from the mains electricity supply.

Remove the syphon and clean it. Refill the condensate trap with clean water and reconnect it with the new O-ring from the inspection set (article nr 0699074). Replace the electrode with seal (parts of inspection set article nr 0699074). Distance between the two pins must be $3,5 \pm 0,5$ mm.

Put the boiler into operation on max. load (see section 5.5). Determine the heat input of the boiler.

Check % CO₂. Repeat for min load. Check the gas-parts for leakages and correct eventually.

Check the flue-gas parts for flue-gas leakages and condensate leakages and correct eventually.

Check for in general for leakages and correct if necessary. Compare the heat input (max and min) with that measured at installation.

If the figures as mentioned in table (chapter 9.1) are comparable the inspection is done.

If the heat input is now considerably lower then there is probably an obstruction in the air inlet or the flue-outlet or in the boiler itself.

Switch off the boiler. Disconnect from the mains electricity supply. First check the air-inlet and the exhaust flue-outlet.

Remove the front cover, top cover and side cover.

Remove the inspection cover* of the sump on the front side beneath the controls.

The inner part of the sump and the bottom part of the heat-exchanger should be inspected and, if necessary, be cleaned.

If the bottom part of the heat-exchanger is clogged, the inspection covers on the left-hand side of the heat-exchanger should be removed*. Using a special tool (see figure 9.1) makes it possible to clean the heat-exchanger lids partially. See page 56 for procedure putting back in place inspection covers on the left-hand side of the heat-exchanger. In case of dirt in the sump it is also advisable to inspect the upper part of the heat-exchanger as well. Remove the fan* together with the burner hood*, the gas valve* and the gas pipe*. Now the burner* is visible and can be taken out and inspected. If necessary clean the cold side with a vacuum cleaner (or carefully with compressed air) and a nylon brush (never use a steel brush). Inspect the combustion chamber. In case of a dirty heat-exchanger it can be cleaned with water. Check the burner seal* and replace if necessary. Tighten with torques as mentioned in 9.3.

Put everything back in its place. Check the CO₂-content and correct if necessary.

Check the gas-parts for leakages.

Check the flue-gas parts for flue-gas leakages and condensate leakages.

***Note:** be careful during inspection not to damage seals.

Any seals damaged by ageing or other causes must be replaced.

Fill in the data in table 9.1

Maintenance (also see 9.1, 9.2, 9.3 and 9.4)

Maintenance set (article nr 0699072) must be used. All parts of the set should be used as replacement. Switch off the boiler. Disconnect from the mains electricity supply. First check the air-inlet and the exhaust flue-outlet.

Remove the front cover, top cover and side cover.

Remove the syphon and clean it.

Remove the inspection cover* of the sump on the front side beneath the controls.

The inner part of the sump and the bottom part of the heat-exchanger must be cleaned.

Remove the inspection covers on the left-hand side of the heat-exchanger*. Using a special tool (see figure 9.1) makes it possible to clean the heat-exchanger lids partially. See next page for procedure putting back in place inspection covers on the left-hand side of the heat-exchanger. Also inspect the upper part of the heat-exchanger. Remove the fan* together with the burner hood*, the gas valve* and the gas pipe*. Now the burner* is visible and can be taken out and inspected. Clean the cold side with a vacuum cleaner (or carefully with compressed air) and a nylon brush (never use a steel brush). Inspect the combustion chamber. In case of a dirty heat-exchanger it must be cleaned with water. Check the burner seal* and replace it by a new one. Tighten with torques as mentioned in 9.3.

Refill the condensate trap with clean water and reconnect it.

Replace the electrode by a new one, check the distance between the two pins ($3,5 \pm 0,5$ mm).

Put everything back in its place. Check the CO₂-content and correct if necessary.

Check the gas-parts for leakages and correct eventually.

Check the flue-gas parts for flue-gas leakages and condensate leakages and correct eventually.

Check for in general for leakages and correct if necessary.

***Note:** be careful during maintenance not to damage seals.

Fill in the data in table 9.1

Procedure putting back in place inspection covers on the left-hand side of the heat-exchanger

First slide the lower bar over the M8 studs

Then mount the lower nuts loose (2-3 rotations)

Then put for each opening and inspection cover foreseen with a seal

Push the bar towards the boiler and fix the nuts hand tight in the sequence as shown in figures beneath.

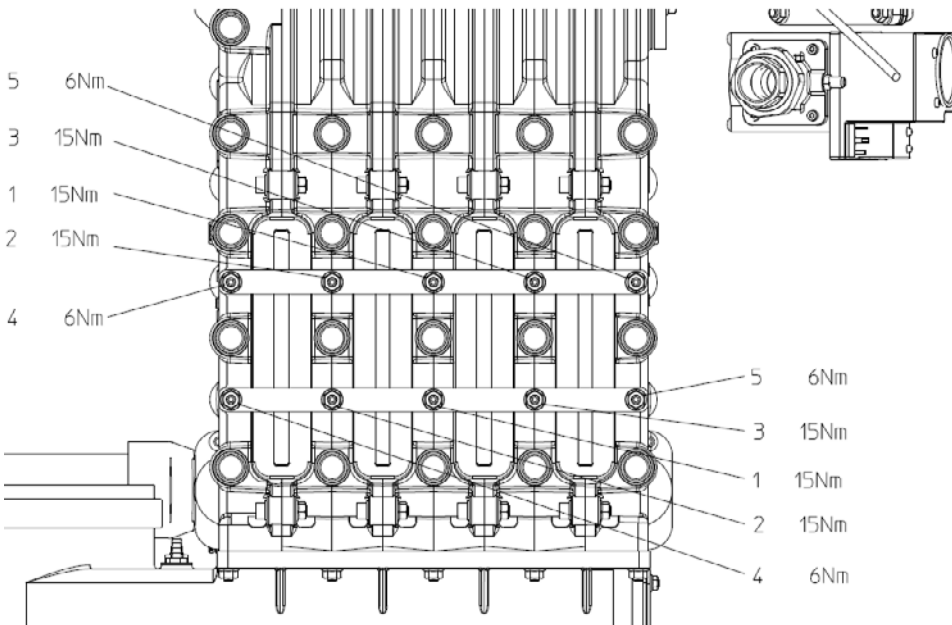
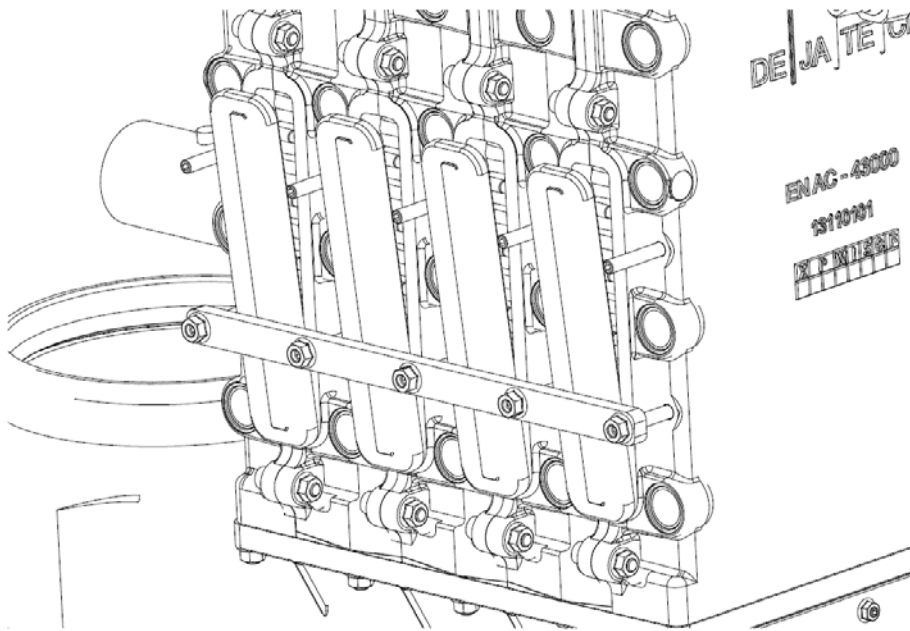

Then slide the upper bar over the M8 studs

Push the bar towards the boiler and fix the nuts hand tight in the sequence as shown in figures above

Fix the nuts of the upper and lower bar in the sequence as shown in figure above with the corresponding torque

The nuts of the middle sections must be tightened with a torque of 15 Nm

Finally, the nuts on the back and the front must be tightened with a torque of 6 Nm

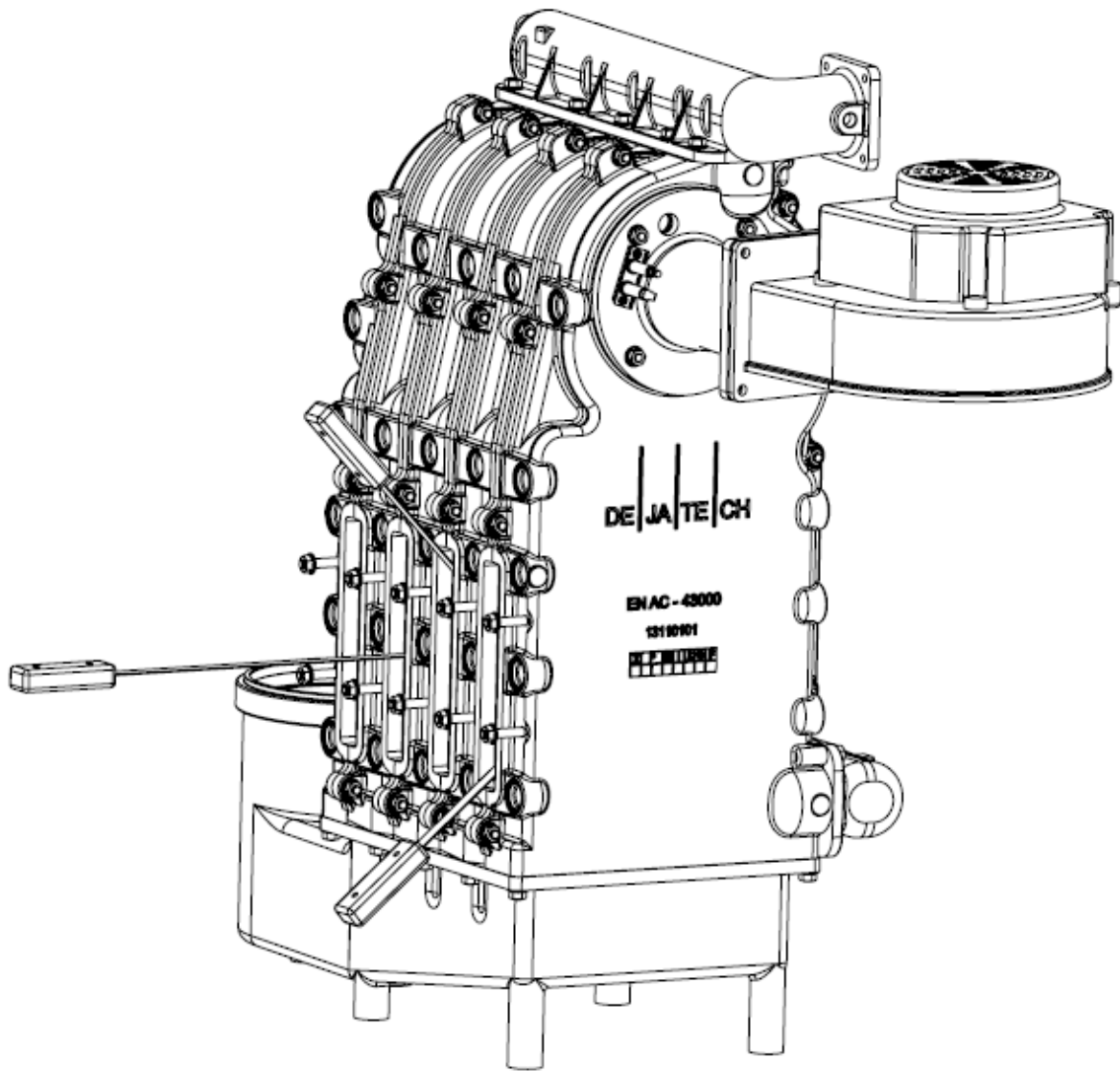

Figure 9.1 special tool for cleaning

9.1 Service-maintenance table

When commissioning/inspecting the boiler CO₂, CO, T flow, T return, ΔP air pressure switch and Syphon pressure switch must be measured and the measured values must be written down in the table below.

Measure these values when the boiler is in equilibrium at maximum load (also see chapter 5.5). Repeat for minimum load.

During annual inspection and maintenance, we advise to measure and write down these values also and compare them to the previous values and analyse any change.

At the factory the maximum load of the boiler was measured within 5% tolerance from the nominal load.

In the field the load can decrease due to increased resistance in the boiler, the air inlet or the exhaust outlet or due to malfunctioning of the fan or other causes.

At maximum load the installation should be designed for nominal ΔT of 15 K to 20 K.

When the ΔT is higher than 25 K, the boiler cannot continue at maximum load anymore and will start to modulate because water flow through the boiler is insufficient.

T flow and T return can be read in "info mode" on the display (see 5.4 diagnostics)

Valves, malfunctioning pumps, dirt, corrosion products from the installation, dirty filters etc. can have negative impact on water flow through the boiler.

Before ignition the boiler control checks ΔP aps during prepurge. During burner operation this check will be carried out. If the value decreases over successive years, this could indicate a problem e.g.

malfunctioning of the fan, dirty air inlet, dirty burner, dirty heat exchanger or dirty exhaust system.

Syphon pressure (P sps) should be lower than the maximum allowable flue resistance. If P sps is too high (> 8,3 mbar), the boiler will be stopped.

In this case the exhaust system may be blocked.

Date	Gasflow [m3/h] or load [kW] max	CO ₂ [%] max	CO [ppm] max	T _{flow} [°C] max	T _{return} [°C] max	P air pressure switch [mbar]	P siphon pressure switch [mbar]	Gasflow [m3/h] or load [kW] max	CO ₂ [%] max	CO [ppm] max	T _{flow} [°C] max	T _{return} [°C] max	P air pressure switch [mbar]	P siphon pressure switch [mbar]
Installed														
Installed + 1 year inspection														
Installed + 2 years maintenance														
Installed + 3 years inspection														
Installed + 4 years maintenance														
Installed + 5 years inspection														

9.2 Tubing and fixation

During the inspection and maintenance also all the tubing and its fixations as shown in the pneumatic diagram in chapter 6.8 must be checked.

Check for leakage and correct fixation. In case of doubt replace tubing and or fixation.

The tubing, especially the P1 connection, are essential for safety and proper functioning of the boiler.

After reconnection of the tubing check for proper functioning of the boiler and also check the input and CO/CO₂ figures (see 7.2)

Also see detail in picture beneath.



9.3 Non return valve NRV in burner hood

For cascade application see document 0660460 Appendix B: Cascade.

During maintenance the outer seal (red part) of the non-return valve must be replaced.

Also check the black foam part for correct closure (sealing)

In case of doubt replace the valve. Also see picture beneath.

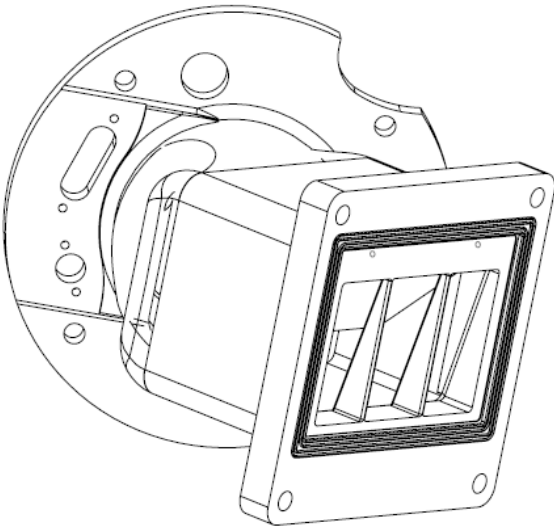

Non return valve in burner hood

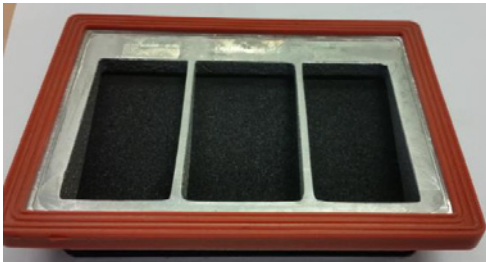

***Note: be careful during inspection/maintenance not to damage seals.**

9.4 Torque table

Concerning part	Torque in Nm
Inspection cover sump	3
Burner hood on heat-exchanger	24
Venturi on fan	12
Fan on burner hood	7
Air-inlet on fan	4
Gas valve on fan	4
Electrode ignition	1,5
Electrode ionisation	1,5
Inspection cover on left-hand side heat-exchanger middle	15
Inspection cover on left-hand side heat-exchanger front	6
Inspection cover on left-hand side heat-exchanger back	6
Manifold return	24
Manifold flow	24
Connection PN flow	-
Connection PN return	-
Water connection on flow manifold	24



CERTIFICATE



Number	18GR0486/03	Replaces	18GR0486/02
Issue date	02-06-2021	Contract number	E1295
Due date	02-06-2031	Module	B (Type testing)
Report number	150401790	Scope	(EU) 2016/426 (9 March 2016)
PIN	0063CQ3790		

EN

EU TYPE EXAMINATION CERTIFICATE (GAR)

Kiwa hereby declares that the condensing central heating boilers, type(s):

**EcoFlex HR 168,
EcoFlex HR 210,
EcoFlex HR 252,
EcoFlex HR 294**

Manufacturer

**Mark B.V.
Veendam, The Netherlands**

meet(s) the essential requirements as described in the
Regulation (EU) 2016/426 relating to appliances burning gaseous fuels.

Reference standard: EN 15502-1:2012+A1:2015 and EN 15502-2-1:2012+A1:2016

This certificate is only valid in combination with the appendix to this certificate, where specific information and/or conditions are given.

Kiwa Nederland B.V.
Wilmsdorf 50
P.O. Box 137
7300 AC APELDOORN
The Netherlands

www.kiwaenergy.com

GASTEC

Ron Scheepers
Kiwa



Number	18GR0486/03	Replaces	18GR0486/02
Issue date	02-06-2021	Contract number	E1295
Due date	02-06-2031	Module	B (Type testing)
Report number	150401790	Scope	(EU) 2016/426 (9 March 2016)
PIN	0063CQ3790	Page	1 of 1

APPENDIX TO EU TYPE EXAMINATION CERTIFICATE (GAR)

Manufacturer:
Mark B.V.

Types:
EcoFlex HR 168, EcoFlex HR 210, EcoFlex HR 252, EcoFlex HR 294

Appliance types:
B23, C₍₁₁₎₃^{*}, C13, C33, C53, C63

Appliance categories:
I2E(R), I2E(S), I2E, I2EK, I2ELL, I2Er, I2Esi, I2H, I2L, I3B/P, I3P, II2E(R)3P, II2E3P, II2EK3P, II2ELL3P, II2Er3P, II2Esi3P, II2H3P, II2L3P

Gas groups and supply pressures:
B/P: 30 mbar; 37 mbar; 50 mbar; P: 30 mbar; 37 mbar; 50 mbar; E: 20 mbar; Er: 20 mbar; 25 mbar; L: 25 mbar;
K: 25 mbar; H: 20 mbar; Esi: 20 mbar; 25 mbar; LL: 20 mbar; E(R): 20 mbar; 25 mbar; E(S): 20 mbar; 25 mbar;

Countries:
Albania, Austria, Belarus, Belgium, Bosnia and Herzegovina, Bulgaria, Croatia, Cyprus, Czech Republic, Denmark, Estonia, Finland, France, Germany, Greece, Hungary, Iceland, Ireland, Italy, Latvia, Liechtenstein, Lithuania, Luxembourg, Macedonia, Malta, Moldova, Montenegro, Norway, Poland, Portugal, Romania, Serbia, Slovakia, Slovenia, Spain, Sweden, Switzerland, Turkey, Ukraine, United Kingdom, the Netherlands

Remarks:
** C₍₁₁₎₃ only valid for horizontally installed cascade systems*

Verklaring • Declaration • Konformitäts-Erklärung • Déclaration



EC DECLARATION OF CONFORMITY, IIA
(EC directive 2006/42/EC relating to machinery)

For the EcoFlex condensing central heating boiler PIN nr.: 0063CQ3790

Description of machinery: 1)

The models EcoFlex HR 168, 210, 252 and 294 are approved.

The undersigned, J.K. de Boer, general manager of Mark B.V., declares that the machines mentioned above, provided that they are installed, maintained and used in accordance with the instructions for use and the codes of practice, meet the essential safety and health requirements of the Machinery directive and the following stipulations and standards:

- | | |
|---------------|--|
| 2) 2006/42/EC | Machinery directive |
| 2014/35/EC | LVD Low voltage directive |
| EN 60204-1 | Electrical equipment of machines |
| 813/2013 | Ecodesign requirements for space heaters and combination heaters |



EG-VERKLARING VAN OVEREENSTEMMING, IIA
(Richtlijn 2006/42/EC betreffende machines)

Voor de machine: 1)

De ondergetekende, J.K. de Boer, algemeen directeur van Mark B.V., verklaart dat de hierboven beschreven machine, als ze is geïnstalleerd, onderhouden en gebruikt wordt in overeenstemming met de gebruiksaanwijzing en de regels van goed vakmanschap, beantwoordt aan de fundamentele veiligheids- en gezondheidseisen van de richtlijn "Machines" en aan de volgende bepalingen en normen: 2)



EG-KONFORMITÄTSERKLÄRUNG, IIA
(Richtlinie 2006/42/EC bezüglich Maschinen)

Für die Maschine: 1)

Der Unterzeichnete, J.K. de Boer, Direktor von Mark B.V., erklärt, dass die oben beschriebene Maschine, wenn sie gemäß Bedienungsanleitung und nach den anerkannten Regeln der Technik installiert, gewartet und gebraucht wird, den grundlegenden Sicherheits- und Gesundheits-Anforderungen der Richtlinie "Maschinen", sowie folgenden Bestimmungen und Normen entspricht: 2)



DECLARATION "CE" DE CONFORMITE, IIA
(Directive 2006/42/CE relative aux machines)

Pour la machine: 1)

La soussignée, J.K. de Boer, directeur général de Mark B.V., déclare que la machine décrite ci-dessus, installée, entretenue et utilisée, conformément à la notice d'instructions et aux règles de bonne pratique, répond aux exigences essentielles pertinentes de la directive "Machines" et aux dispositions et normes suivantes: 2)



Veendam, 05 June 2018

Signature :

Name :
Qualification :

J.K. de Boer
General manager

MANUFACTURER:

MARK B.V.
Beneden Verlaat 87-89, 9645 BM Veendam
Postbox 13, 9640 AA Veendam
Tel. +31 (0)598 656600
Fax. +31 (0)598 624584
E-mail info @ mark.nl

480-04_20180605

<p>ES DECLARATION DE CONFORMIDAD 'CE' (Directiva 2006/42/EC sobre maquinaria para máquinas 1)</p> <p>El suscrito, J.K. de Boer, autorizado por Mark B.V., certifica que la máquina anteriormente descrita, a condición de que esté instalada, mantenida y utilizada según las instrucciones para su uso y los datos técnicos de utilización, cumple con los requisitos de seguridad y de salud de la Directiva "máquinas" y las especificaciones y normas siguientes 2):</p>	<p>DK EC-DEKLARATION (EC direktiv 2006/42/EC om maskiner til maskinen 1)</p> <p>Undertegnede, J.K. de Boer, autoriseret af Mark B.V., bekræfter at maskinen beskrevet ovenfor, forudsat at den installeres, vedligeholdes og bruges som angivet i brugervejledningen, opfylder de sikkerhedskrav som er angivet i 'maskindirektivet' og de følgende standarder 2):</p>
<p>LT EC ATITIKTIES DEKLARACIJA, IIA (Direktyva 2006/42/EC dėl mašinų mašinoms 1)</p> <p>Pasirašiusysis, J.K. de Boer, Mark B.V. direktorius, pareiškia, kad anksčiau nurodytas prietaisas, jei jis įrengtas, prižiūrimas ir naudojamas pagal pateiktus nurodymus ir praktikos taisyklės, atitinka svarbiausius saugos ir sveikatos reikalavimus, išdėstytus Mašinų direktyvoje ir šiuose nuostatuose bei standartuose 2):</p>	<p>NO EC SAMSVARS ERKLÆRING (EC Direktiv 2006/42/EC om maskineri for maskinen 1)</p> <p>Undertegnede, J.K. de Boer, autorisert av Mark B.V., erklærer at maskinen beskrevet over, under forutsetning at den er installert, vedlikeholdt og brukt i henhold til bruksanvisningen og allmen praksis, er i samsvar med de angitte krav til sikkerhet og helse angitt i 'maskin' Direktivet og følgende standarder 2):</p>
<p>IT Dichiarazione di conformità CE, IIA (Direttiva Macchine 2006/42/EC relativa alle macchine per macchine 1)</p> <p>Il sottoscritto, J.K. de Boer, autorizzato dalla Mark B.V., certifica che la macchina sopra specificata, tenuto conto che sia installata, usata e fornita di adeguata manutenzione periodica secondo le istruzioni d'uso e le procedure pratiche, rispetta le essenziali norme sanitarie e di sicurezza della Direttiva Macchine e le seguenti norme e convenzioni 2):</p>	<p>SE EC DEKLARATION (EC Direktiv 2006/42/EC om maskiner för maskinerna 1)</p> <p>Undertecknad, J.K. de Boer, auktoriserad av Mark B.V., intygat att maskinen enl. ovan, under förutsättning att den installerats, underhållits och används i enlighet med instruktionerna samt allmän praxis, uppfyller ställda krav på säkerhet och hälsa angiven i 'maskin' Direktiven och nedanstående standard 2):</p>
<p>CZ EC PROHLÁŠENÍ O ZPŮSOBILOSTI (Směrnice 2006/42/EC o strojních zařízeních pro stroje 1)</p> <p>Níže podepsaný J.K. de Boer, generální ředitel společnosti Mark B.V., prohlašuje, že výše uvedené strojní zařízení, za předpokladu, že jsou instalována, udržována a používána v souladu s návodem k použití a praktickými manuály, vyhovují nezbytným bezpečnostním a zdravotním požadavkům Směrnice týkající se strojních zařízení a následujících dohod a norem 2):</p>	<p>FI EC-VAATIMUSTENMUKAISUUSVAKUUTUS (Direktiivi 2006/42/EC koneista koneille 1)</p> <p>Allekirjoittaja, Mark B.V.:n toimitusjohtaja J.K. de Boer, vakuuttaa, että yllä kuvattu kone, silloin kun se on asennettu, huollettu ja sitä käytetään käyttöohjeiden ja hyvien työtapojen mukaisesti, täyttää konedirektiivissä säädetty olennaiset turvallisuutta ja terveyttä koskevat vaatimukset ja seuraavien säädösten ja standardien vaatimukset 2):</p>
<p>TR AT UYGUNLUK BEYANI, IIA (Makinelerle ilgili 2006/42 / EC sayılı Direktifmakinelere için 1)</p> <p>□Aşağıda imzası bulunan, Mark B.V. Genel Müdürü J.K. de Boer, yukarıda adı geçen makinelerin, kullanma talimatları ve uygulama kuralları uyarınca kurulmaları, bakım görmeleri ve kullanılmaları kaydıyla, Makinelere ilişkin yönergenin başlıca güvenlik ve sağlık gerekliliklerini ve aşağıdaki koşullar ve standartları karşıladığını beyan eder 2):</p>	<p>GR DHLVSH SYMNOR FVSHE ME ODHGIES THE EYRPAIKHS ENVSHS (Οδηγία 2006/42 / ΕΚ σχετικά με τα μηχανήματα για μηχανές 1)</p> <p>Ο katvui ypogrammeyw J.K. de Boer, ejoysiofthmewow apo thy Mark B.V., piotopiv oti to ayterv perigrawomeno mhxanhma ypo thn proypouesh oti eivai egkatesthmeno kai s ynthrmeno svata kauvw kai oti xrhsmopoietai symwnna me tiz oshgiez xrhsevz kai thy koiyh praktikh aytaokriyetai stiz basikez apaitheisz aswaleiaz kai ygieiyhz thz peri mhxyikyoy ejoplismoy kai stoyz akoloyuoyz oroyz kai prodiagrawez 2):</p>
<p>HU EC MEGFELELŐSÉGI NYILATKOZAT, IIA (2006/42/EC irányelv a gépekről gépekhez 1)</p> <p>Alulírott, J.K. de Boer, a Mark B.V. ügyvezető igazgatója, kijelentem, hogy a fentiekben leírt gép - feltéve, hogy a használati utasítás és az eljárási szabályzat szerinti helyezték üzembe, tartották karban és használták - megfelel a gépekre vonatkozó irányelv lényeges biztonsági és egészségügyi előírásainak, valamint az alábbi rendelkezéseknek és szabványoknak 2):</p>	<p>RO EC DECLARAȚIE DE CONFORMITATE, IIA (Directiva 2006/42/CE privind echipamentele tehnice pentru mașini 1)</p> <p>Subsemnatul, J.K. de Boer, director general al Mark B.V., declar că utilajele menționate mai sus, cu condiția ca ele să fie instalate în conformitate cu instrucțiunile de utilizare și codurile regulile de bună practică, respectă cerințele esențiale de siguranță și sănătate din directiva Utilaje și următoarele prevederi și standarde 2):</p>
<p>PL DEKLARACJA ZGODNOŚCI CE, IIA (Dyrektywa 2006/42/CE w sprawie maszyn dla maszyn 1)</p> <p>Niżej podpisany J.K. de Boer, dyrektor generalny firmy Mark B.V., deklaruje, że maszyny wymienione powyżej, o ile ich instalacja, konserwacja i eksploatacja jest zgodna z instrukcją obsługi i kodeksami praktyki, spełniają podstawowe wymagania bezpieczeństwa i higieny pracy określone w dyrektywie oraz następujących przepisach i normach 2):</p>	<p>SK VYHLÁSENIE O ZHODE V RÁMCI ES, IIA (Smernica 2006/42/EC o strojových zariadeniach pre stroje 1)</p> <p>Dolupodpísaný J.K. de Boer, generálny riaditeľ spoločnosti Mark B.V. týmto vyhlasuje, že vyššie uvedené stroje, za predpokladu, že sa nainštalovali, že sa na nich vykonáva údržba a že sa používajú v súlade s návodom na používanie a zaužívanými postupmi, spĺňajú základné požiadavky na bezpečnosť a ochranu zdravia vyplývajúce zo smernice o strojových zariadeniach a nasledujúcich ustanovení a noriem:2)</p>

MARK BV

BENEDEN VERLAAT 87-89
VEENDAM (NEDERLAND)
POSTBUS 13, 9640 AA VEENDAM
TELEFOON +31(0)598 656600
FAX +31 (0)598 624584
info@mark.nl
www.mark.nl

MARK EIRE BV

COOLEA, MACROOM
CO. CORK
P12 W660 (IRELAND)
PHONE +353 (0)26 45334
FAX +353 (0)26 45383
sales@markeire.com
www.markeire.com

MARK BELGIUM b.v.b.a.

ENERGIELAAN 12
2950 KAPELLEN
(BELGIË/BELGIQUE)
TELEFOON +32 (0)3 6669254
info@markbelgium.be
www.markbelgium.be

MARK DEUTSCHLAND GmbH

MAX-PLANCK-STRASSE 16
46446 EMMERICH AM RHEIN
(DEUTSCHLAND)
TELEFON +49 (0)2822 97728-0
TELEFAX +49 (0)2822 97728-10
info@mark.de
www.mark.de

MARK POLSKA Sp. z o.o

UL. JASNOGÓRSKA 27
42-202 CZĘSTOCHOWA (POLSKA)
PHONE +48 34 3683443
FAX +48 34 3683553
info@markpolska.pl
www.markpolska.pl

MARK SRL ROMANIA

STR. BANEASA NO 8 (VIA STR. LIBERTATII)
540199 TÂRGU-MURES, JUD MURES
(ROMANIA)
TEL/FAX +40 (0)265-266.332
office@markromania.ro
www.markromania.ro

