

### External connections

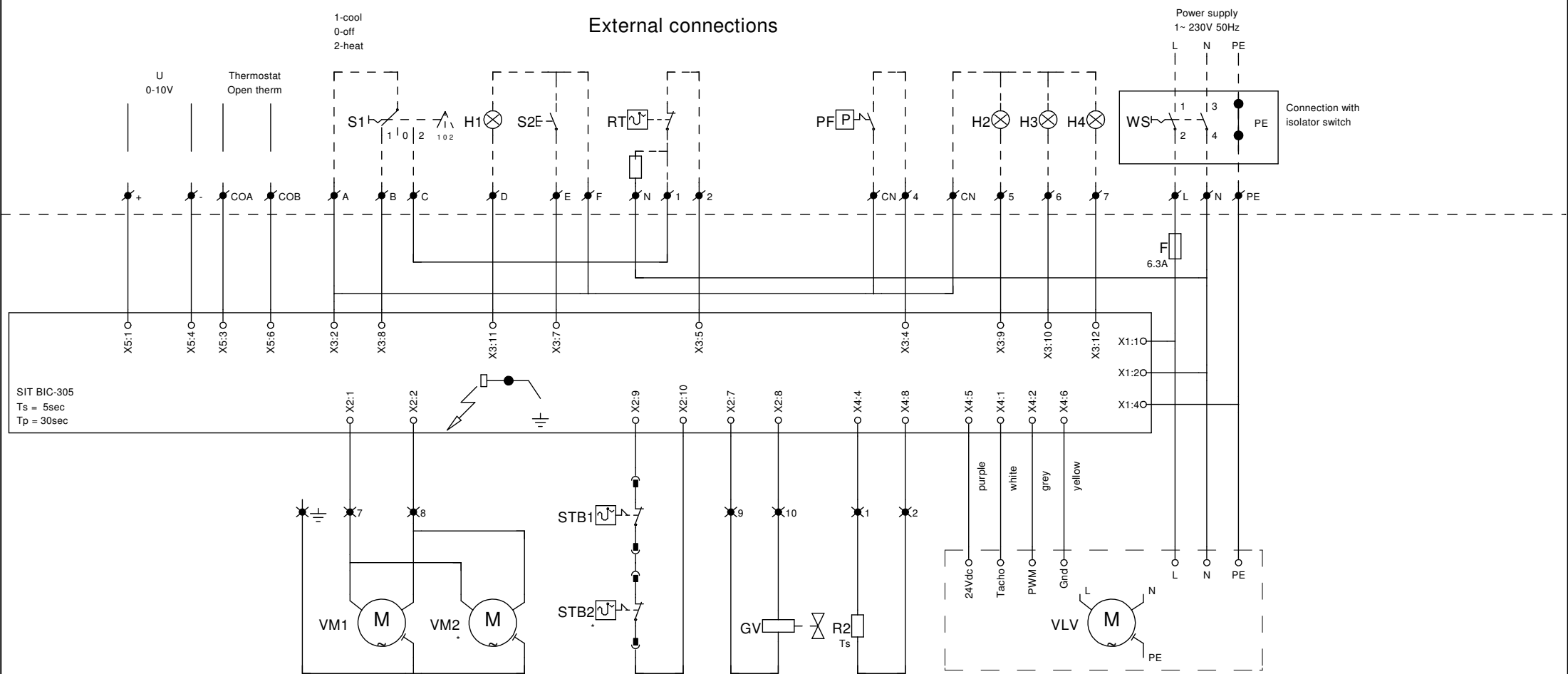

\* for heaters with two fans

- |    |                                    |           |                      |   |                    |
|----|------------------------------------|-----------|----------------------|---|--------------------|
| F  | - Fuse                             | S1        | - Selector switch    | ↙ | Connector strip XA |
| GV | - Gasvalve                         | S2        | - Reset button       | ↘ | Connector strip XB |
| H1 | - Signal light burner failure      | STB1/STB2 | - Safety thermostat  |   |                    |
| H2 | - Signal light burner on           | VLV       | - Combustion air fan |   |                    |
| H3 | - Signal light maximum temperature | VM1/VM2   | - Fan motor          |   |                    |
| H4 | - Signal light dirty filter        | WS        | - Isolator switch    |   |                    |
| PF | - Filter pressure switch           |           |                      |   |                    |
| R2 | - System air temperature sensor    |           |                      |   |                    |
| RT | - Room thermostat                  |           |                      |   |                    |